



# F261 Series Fluid Flow Switches

## Product Bulletin

Code No. LIT-12011987  
 Issued July 22, 2015

Refer to the [QuickLIT website](#) for the most up-to-date version of this document.

The F261 Series Flow Switches respond to fluid flow in lines carrying water, ethylene glycol, or other nonhazardous fluids. These models also work in applications with swimming pool water and lubricating oils.

**F261 Series Standard Flow Switches** use a variety of paddle sizes to respond to fluid flow rates in applications with 1 inch trade size (or greater) pipe.

**F261 Series Low Flow Switches** respond to low fluid flow rates in applications with 1 inch trade size (or less) pipe.

A low-energy model with gold-plated contacts provides improved electrical performance in low-voltage, low-current circuits (dry circuits) to switch low-energy resistive loads, such as control signals.



Figure 1: F261KAH Flow Switch

Table 1: Features and Benefits

Features	Benefits
<b>Type 3R (NEMA) or Type 4 (NEMA) Polycarbonate Enclosure</b>	Provides dust protection in indoor and outdoor applications.
<b>Viton® Diaphragm</b>	Allows use in fluid lines carrying chlorinated water, treated water, or other nonhazardous fluids.
<b>Low-Flow Operation on Low-Flow Models</b>	Actuates switch with less than 2.0 GPM (7.6 L/min) flow for water applications or 11.0 GPM (41.6 L/min) flow for steam applications.
<b>Gold-Plated Contacts on Selected Models</b>	Reduce intermittent contact problems in low-voltage and low-current circuits (dry circuits).
<b>Maximum Fluid Pressure of 290 psig (20 bar)</b>	Permits use in a wide range of pressure flow conditions.

## Application

**IMPORTANT:** All F261 Series Flow Switches are intended to control equipment under normal operating conditions. Where failure or malfunction of an F261 Flow Switch could lead to an abnormal operating condition that could cause personal injury or damage to the equipment or other property, other devices (limit or safety controls) or systems (alarm or supervisory) intended to warn of, or protect against, failure or malfunction of the F261 Flow Switch must be incorporated into and maintained as part of the control system.

**IMPORTANT:** Do not install or use this F261 Series Flow Switch in or near environments where corrosive substances or vapors could be present. Exposure of the F261 Series Flow Switch to corrosive environments may damage the device's internal components and will void the warranty.

**IMPORTANT:** Do not use F261 Series Flow Switches where the fluid in the pipes drops below the fluid's freezing point, causing an internal freeze-up.

### Standard Flow Switches

Use F261 Series Standard Flow Switches in applications with fluid pressures up to 290 psig (20 bar). A typical application for a standard F261 flow switch is to shut down the refrigeration compressor on a fluid chiller system if flow stops, reducing chances of chiller freeze-ups.

### Low-Flow Switches

The F261 Series Low-Flow Switches have 1/2 in. Female NPTF or 3/4 in. Female NPTF inlet and outlet connections.

Use F261 Low-Flow Switches in applications where flow rates are low, such as:

- water purification and treatment systems
- booster pumps
- cooling systems for electronic tubes, bearings, and compressors
- rapid recovery water heaters (starting the water heater when water is withdrawn)
- control of food waste disposal units (starting the motor when a predetermined amount of water is flowing through the unit and stopping when the flow decreases to a predetermined rate)

- switch to shut down the refrigeration compressor on a fluid chiller system if flow stops, reducing chances of chiller freeze-ups

### Low-Energy Flow Switches with Gold-Plated Contacts

Models with gold-plated contacts provide improved electrical performance in low-voltage, low-current circuits (dry circuits). Use these models to switch low-energy resistive loads, such as control signals.

### Type 3R (NEMA) / IP43 Enclosures

Use models with Type 3R (NEMA) / IP43 enclosures for indoor or outdoor applications where they are protected from weather and splashing water. Use these models with pipes carrying fluids at temperatures in the range of -20°F to 250°F (-29°C to 121°C). A drain hole allows Type 3R (NEMA) models to be used in applications where the fluid temperature is below the ambient dew point temperature. The drain hole knockout is plugged on IP43 models to prevent the intrusion of objects 1 mm Ø and greater. Removing the plug reduces the enclosure rating to IP23, allowing these models to be used in applications where the fluid temperature is below the ambient dew point temperature. Do not use these models in applications or environments where the temperature may cause the fluid to freeze.

### Type 4 (NEMA) / IP67 Enclosures

Use models with Type 4 (NEMA) enclosures for indoor or outdoor applications in high humidity environments. Use these models with pipes carrying fluids at temperatures in the range of -20°F to 250°F (-29°C to 121°C). A sealing O-ring between the cover and case allows these models to be used in high-humidity environments, or applications where the fluid temperature is below the ambient dew point temperature. Do not use these models in applications or environments where the temperature may cause the fluid to freeze.

### Media Compatibility

F261 Series Flow Switches are compatible with several common media:

- water
- ethylene glycol
- brine
- sea water
- swimming pool water
- lubricating oils

## Dimensions

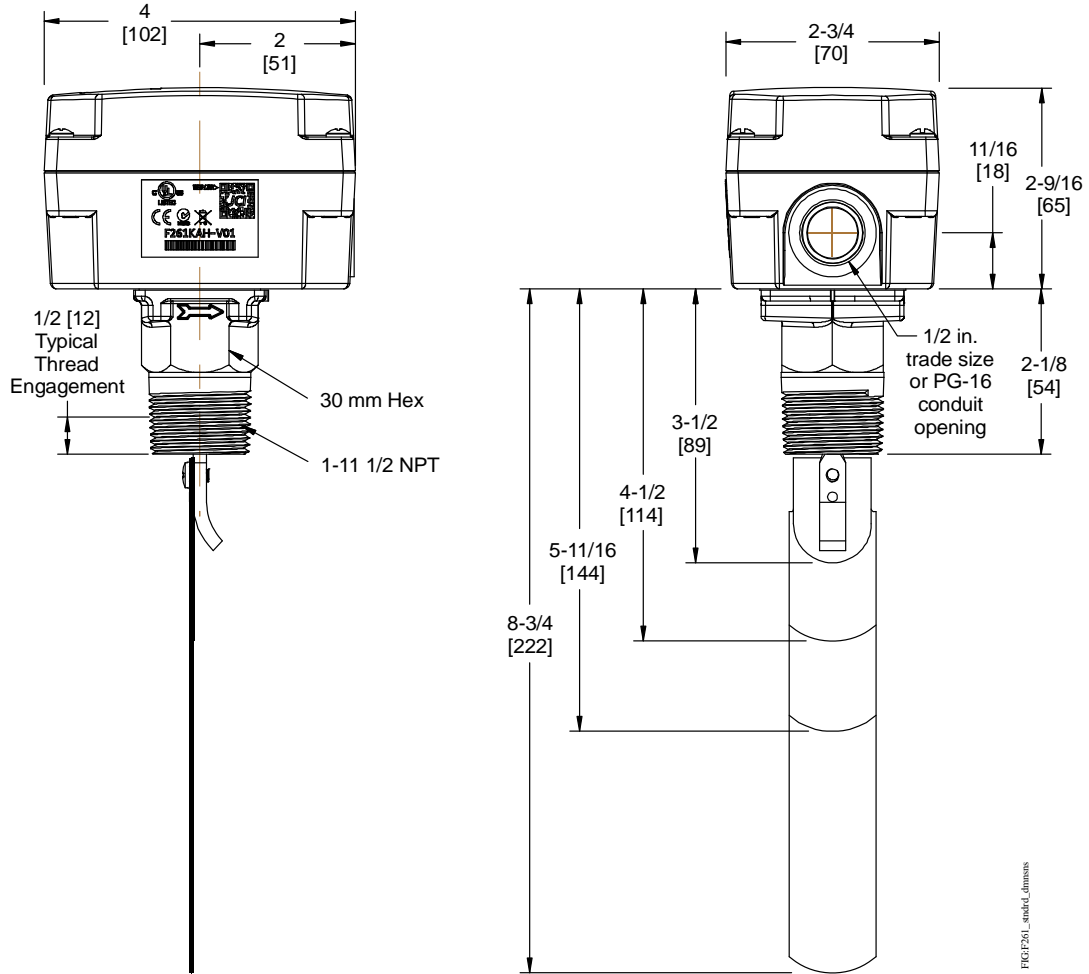

Figure 2: Dimensions for F261 Standard Flow Switch, in. [mm]

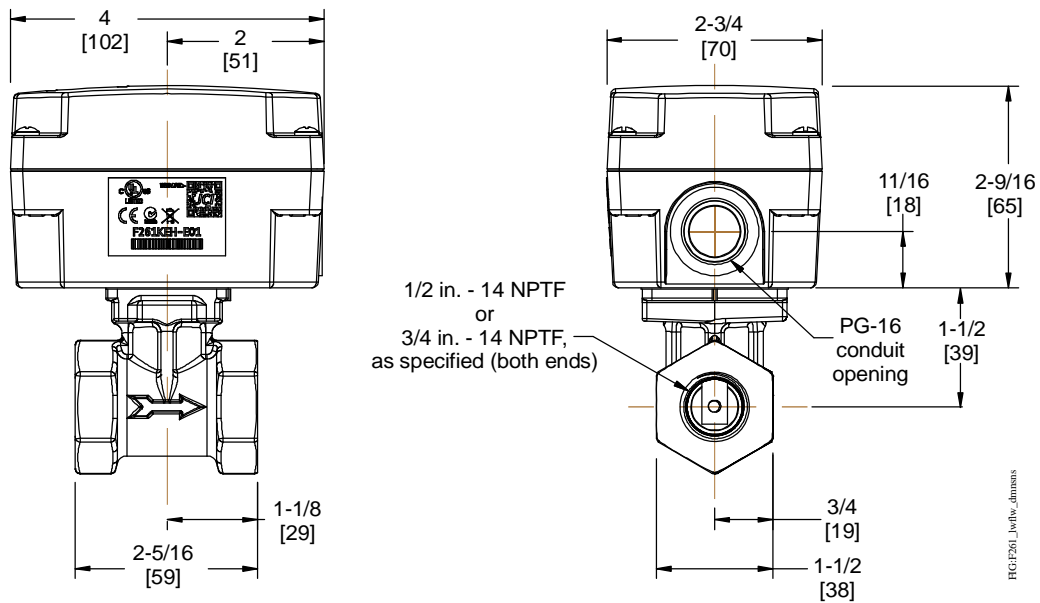

Figure 3: Dimensions for F261 Low-Flow Switch, in. [mm]

## Operation

The flow switch responds to pressure exerted on the fluid paddle by the flowing fluid. A range adjustment screw adjusts the rate of the flow required to activate the switch. See Table 3 through Table 8 for flow rates.

The red terminal is the Common. Red to Yellow closes on flow increase. Red to Blue closes on flow decrease.

**Table 2: F261 Switch Action**

Flow Action	Switch Closure
Increase	Red to Yellow
Decrease	Red to Blue

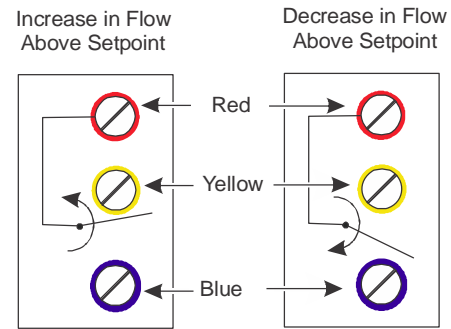

**Figure 4: F261 Control Switch Action**

**Table 3: Flow Rates for Standard Models, 1-3 in. Paddles**

		GPM (m <sup>3</sup> /hr) Required to Activate Switch for Pipe Size (in.)									
		1	1-1/4 <sup>1</sup>	1-1/2 <sup>1</sup>	2	2-1/2 <sup>2</sup>	3	4 <sup>3</sup>	5 <sup>3</sup>	6 <sup>3</sup>	8 <sup>3</sup>
<b>Minimum Adjustment</b>	Flow Increase (Close R to Y)	4.20 (0.95)	5.80 (1.32)	7.50 (1.70)	13.7 (3.11)	18.0 (4.09)	27.5 (6.24)	65.0 (14.8)	125 (28.4)	190 (43.2)	375 (85.2)
	Flow Decrease (Close R to B)	2.50 (0.57)	3.70 (0.84)	5.00 (1.14)	9.50 (2.16)	12.5 (2.84)	19.0 (4.32)	50.0 (11.4)	101 (22.9)	158 (35.9)	320 (72.7)
<b>Maximum Adjustment</b>	Flow Increase (Close R to Y)	8.80 (2.0)	13.3 (3.02)	19.2 (4.36)	29.0 (6.59)	34.5 (7.84)	53.0 (12.0)	128 (29.1)	245 (55.6)	375 (85.2)	760 (173)
	Flow Decrease (Close R to B)	8.50 (1.93)	12.5 (2.84)	18.0 (4.09)	27.0 (6.13)	32.0 (7.27)	50.0 (11.4)	122 (27.7)	235 (53.4)	360 (81.8)	730 (166)

1. Values for 2 in. paddle trimmed to pipe.
2. Values for a 3 in. paddle trimmed to fit pipe.
3. Values calculated for a factory-installed set of 1, 2, and 3 in. paddles.

**Table 4: Flow Rates for Standard Models, 6 in. Paddles**

		GPM (m <sup>3</sup> /hr) Required to Activate Switch for Pipe Size (in.)			
		4	5	6	8
<b>Minimum Adjustment</b>	Flow Increase (Close R to Y)	37.0 (8.40)	57.0 (12.9)	74.0 (16.8)	205 (46.6)
	Flow Decrease (Close R to B)	27.0 (6.13)	41.0 (9.31)	54.0 (12.3)	170 (38.6)
<b>Maximum Adjustment</b>	Flow Increase (Close R to Y)	81.0 (18.4)	118 (26.8)	144 (32.7)	415 (94.3)
	Flow Decrease (Close R to B)	76.0 (1.93)	111 (25.2)	135 (30.7)	400 (90.8)

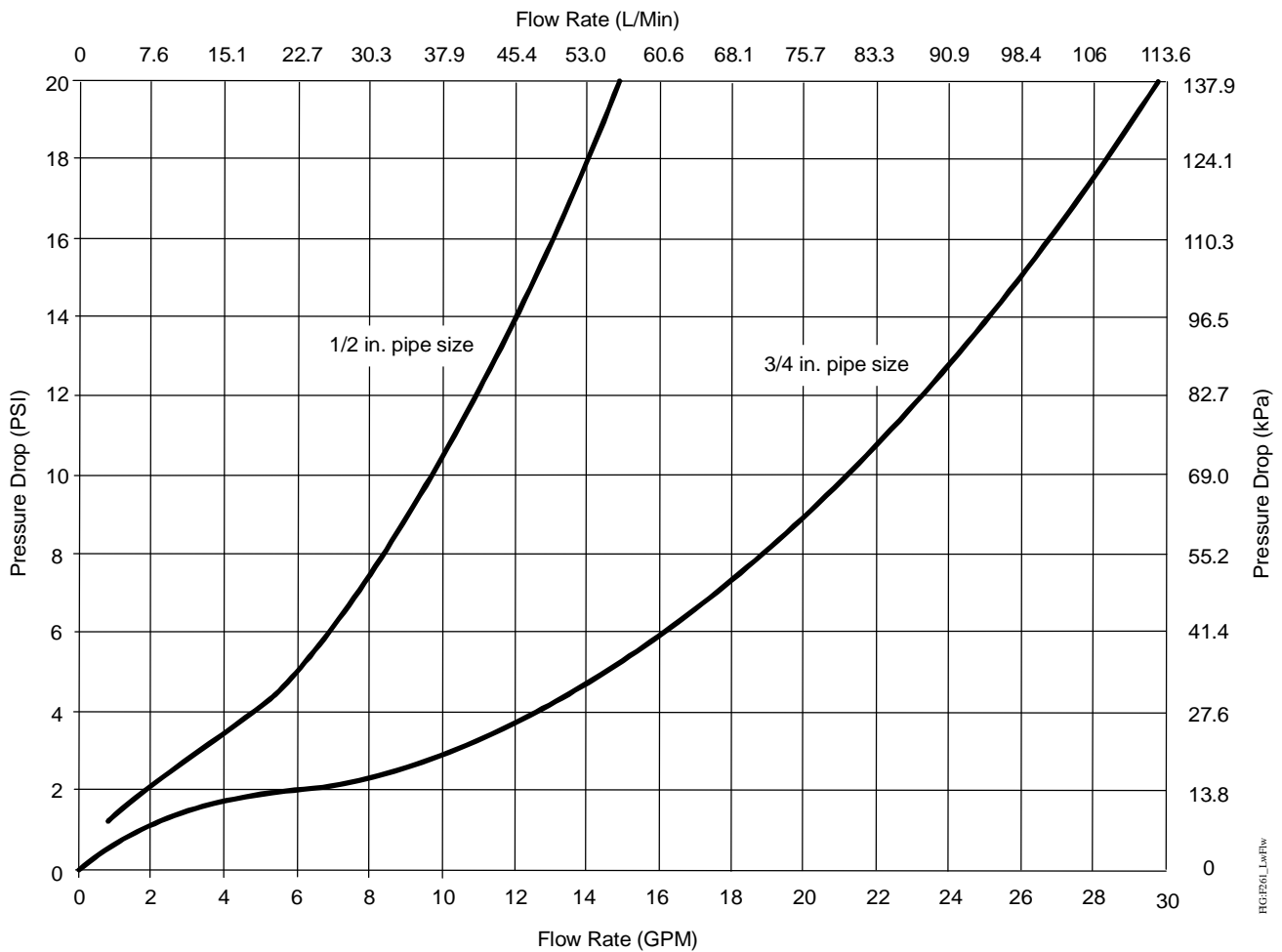

**Figure 5: Pressure Drop versus Flow Rate, F261 Series Low-Flow Switches (F261KEH-V01C, F261MEH-V01C, F261KFH-V01C, F261MFH-V01C)**

**Table 5: GPM (L/Min) Required to Actuate F261 Series Low Flow Switches**

		Pipe Size		
		1/2 x 1/2 in. Female NPTF <sup>1</sup>	3/4 x 3/4 in. Female NPTF <sup>2</sup>	3/4 x 3/4 in. Female NPTF <sup>3</sup>
<b>Minimum Adjustment</b>	Flow Increase (R to Y Closes)	1.30 (4.92)	2.00 (7.57)	10.90 (41.26)
	Flow Decrease (R to B Closes)	0.60 (2.27)	0.60 (2.27)	7.20 (27.25)
<b>Maximum Adjustment</b>	Flow Increase (R to Y Closes)	2.60 (9.84)	3.60 (13.63)	17.00 (64.35)
	Flow Decrease (R to B Closes)	1.25 (4.73)	1.30 (4.92)	14.20 (53.75)

1. F261KEH-V01C, F261MEH-V01C
2. F261KFH-V01C, F261MFH-V01C
3. F261KFH-V02C (designed for steam applications)

## Ordering Information

### F61 to F261 Cross-Reference Tables

**Table 6: Standard Flow Models Cross Reference**

F61 Series Model	F261 Series Model
F61KB-11C	F261KAH-V01C
F61LB-1C	F261MAH-V01C
F61MB-1C	F261MAH-V01C
F61MB-5C	F261MAH-V01C

**Table 7: Low-Flow Models Cross Reference**

F61 Series Model	F261 Series Model
F61KD-3C	F261KEH-V01C
F61KD-4C	F261KFH-V01C
F61KD-8C	F261KFH-V02C
F61MD-1C	F261MEH-V01C
F61MD-2C	F261MFH-V01C

### Selection Tables

**Table 8: F261 Series Standard Model Flow Switches**

Product Code Number	Description
F261KAH-V01C	Standard model flow switch with Type 3R (NEMA) enclosure; 1 in., 2 in., 3 in., and 6 in. stainless steel paddles, lock-tooth washer, and stainless steel paddle screw supplied uninstalled
F261MAH-V01C	Standard model flow switch with Type 4 (NEMA) enclosure; 1 in., 2 in., 3 in., and 6 in. stainless steel paddles, lock-tooth washer, and stainless steel paddle screw supplied uninstalled
F261MAL-V01C <sup>1</sup>	Standard model flow switch with Type 4 (NEMA) enclosure; 1 in., 2 in., 3 in., and 6 in. stainless steel paddles, lock-tooth washer, and stainless steel paddle screw supplied uninstalled

1. This model is a low-energy flow switch with gold-plated electrical contacts.

**Table 9: F261 Series Low-Flow Model Flow Switches**

Product Code Number	Description
F261KEH-V01C	Low-flow model flow switch with Type 3R (NEMA) enclosure 1/2 in. x 1/2 in. Female NPTF inlet and outlet
F261KFH-V01C	Low-flow model flow switch with Type 3R (NEMA) enclosure; 3/4 in. x 3/4 in. Female NPTF inlet and outlet
F261KFH-V02C	Low-flow model flow switch with Type 3R (NEMA) enclosure; 3/4 in. x 3/4 in. Female NPTF inlet and outlet
F261MEHV01C	Low-flow model flow switch with Type 4 (NEMA) enclosure; 1/2 in. x 1/2 in. Female NPTF inlet and outlet
F261MFH-V01C	Low-flow model flow switch with Type 4 (NEMA) enclosure; 3/4 in. x 3/4 in. Female NPTF inlet and outlet

**Table 10: Replacement Paddle Parts**

Product Code Number	Description
KIT21A-600	Stainless steel 3-piece paddle (3 in., 2 in., and 1 in. segments)
KIT21A-601	Stainless steel 6 in. paddle
KIT21A-602	Stainless steel 3-piece paddle (3 in., 2 in., and 1 in. segments) and Stainless steel 6 in. paddle

## Repair Information

Do not make field repairs, except for replacement of the flow paddle. For a replacement control or paddle kit, contact the nearest Johnson Controls/PENN distributor. For more information, contact Johnson Controls/PENN application engineering at 1-800-275-5676 or 1-414-524-5535.

## Technical Specifications

Table 11: F261xxH Series Standard Controls Electrical Ratings

Volts 50/60 Hz	UL60730/UL1059				EN60730	
	24 VAC	120 VAC	208 VAC	240 VAC	24 VAC	230VAC
Horsepower	–	1	1	1	–	–
Full Load Amperes	–	16	10	10	–	8
Locked Rotor Amperes	–	96	60	60	–	48
Resistive Amperes	16	16	10	10	16	16
Pilot Duty VA	125	720	720	720	77	720

Table 12: F261xxL Series Low Energy Controls Electrical Ratings, AC Current

Volts AC, 50/60 Hz	UL60730/UL1059/EN60730		
	4 VAC	24 VAC	120 VAC
Resistive Amperes <sup>1</sup>	10	10	10
Pilot Duty VA <sup>2</sup>	12	72	360

1. **Maximum Dry Circuit Rating:** Resistive only, 400 mW at 28 VAC/VDC.  
Once a relay has been used at the General Rating level, the Dry Circuit Rating is no longer valid.
2. Meets UL 100,000 cycle UL endurance test requirement at switch with  $T_{min}$  greater than or equal to 32°F (0°C).

Table 13: F261xxL Series Low Energy Controls Electrical Ratings, DC Current

Volts DC	UL60730/UL1059/EN60730		
	4 VDC	24 VDC	48 VDC
Resistive Amperes <sup>1</sup>	1	1	1

1. **Maximum Dry Circuit Rating:** Resistive only, 400 mW at 28 VAC/VDC.  
Once a relay has been used at the General Rating level, the Dry Circuit Rating is no longer valid.

Table 14: UL Conformity Declaration Information (Part 1 of 2)

Information	Description
Purpose of Control	F261 Fluid Flow Switch
Construction of Control	Electronic independently mounted control
Number of Cycles	100,000 cycles
Method of Mounting Control	Mounting to sensed media vessel/orientation
Type 1 or Type 2 Action	Type 1.C (Microinterruption)
External Pollution Situation	Pollution degree 4
Internal Pollution Situation	Pollution degree 2
Rated Impulse Voltage	4,000 VAC
Ball Pressure Temperature	<b>Enclosure:</b> 266°F (130°C ) <b>Switch Component:</b> 252°F (122°C)
Control Adjustment Instruction	-

**Table 14: UL Conformity Declaration Information (Part 2 of 2)**

<b>Field Wiring Rating</b>	<b>Wire/Cord Temperature Ratings:</b> <ul style="list-style-type: none"> <li>• 140°F (60°C) only permitted when ambient air and media are less than 113°F (45°C)</li> <li>• 167°F (75°C) only permitted when ambient air and media are less than 140°F (60°C)</li> <li>• 194°F (90°C) only permitted when ambient air is less than 140°F (60°C) and media is less than 167°F (75°C)</li> <li>• 302°F (150°C) permitted when ambient air is less than 140°F (60°C) and media is less than 249°F (121°C)</li> </ul>
<b>Vessel Pressure</b>	<b>F261 Fluid Flow Switch:</b> 290 psi (20 Bar)

**F261 Series Fluid Flow Switches**

<b>Switch</b>	SPDT
<b>Enclosure</b>	<b>UL:</b> Type 3R or Type 4 <b>CE:</b> IP43 (IP23 with drain hole plug removed) or IP67
<b>Wiring Connections</b>	Three color-coded screw terminals and one ground terminal
<b>Conduit Connection</b>	One 7/8 in. (22 mm) hole for 1/2 in. trade size (or PG16) conduit
<b>Pipe Connector</b>	<b>Standard:</b> 1 in. 11-1/2 NPT Threads <b>Low-Flow:</b> 1/2 in. x 1/2 in. Female NPTF; 3/4 in. x 3/4 in. Female NPTF
<b>Maximum Fluid Pressure</b>	290 psi (20 bar)
<b>Minimum Fluid Temperature<sup>1</sup></b>	-20°F (-29°C)
<b>Maximum Fluid Temperature<sup>2</sup></b>	250°F (121°C)
<b>Ambient Conditions</b>	-40 to 140°F (-40 to 60°C)
<b>Compliance</b>  	<b>North America:</b> cULus Listed; UL 60730, File E6688; FCC Compliant to CFR47, Part 15, Subpart B, Class B Industry Canada (IC) Compliant to Canadian ICES-003, Class B limits
	<b>Europe:</b> CE Mark – Johnson Controls, Inc. declares that this product is in compliance with the essential requirements and other relevant provisions of the EMC Directive and the Low Voltage Directive.
	<b>Australia/New Zealand Mark:</b> RCM Compliant

1. Ensure that the low liquid temperature combined with the low ambient temperature does not lead to the freezing the liquid inside the body (or bellows, where appropriate). Please observe the liquid freezing point.
2. At higher ambient temperatures, the maximum allowed liquid temperature becomes lower. The temperature of the electrical switch inside should not exceed 158°F (70°C).

*The performance specifications are nominal and conform to acceptable industry standards. For application at conditions beyond these specifications, consult Johnson Controls/PENN Refrigeration Application Engineering at 1-800-275-5676. Johnson Controls, Inc. shall not be liable for damages resulting from misapplication or misuse of its products.*



### **United States Emissions Compliance**

*This equipment has been tested and found to comply with the limits for a Class B digital device, pursuant to Part 15 of the FCC Rules. These limits are designed to provide reasonable protection against harmful interference in a residential installation. This equipment generates, uses and can radiate radio frequency energy and, if not installed and used in accordance with the instructions, may cause harmful interference to radio communications. However, there is no guarantee that interference will not occur in a particular installation. If this equipment does cause harmful interference to radio or television reception, which can be determined by turning the equipment off and on, the user is encouraged to try to correct the interference by one or more of the following measures:*

- Reorient or relocate the receiving antenna.
- Increase the separation between the equipment and receiver.
- Connect the equipment into an outlet on a circuit different from that to which the receiver is connected.
- Consult the dealer or an experienced radio/TV technician for help.

### **Canadian Emissions Compliance**

*This Class (B) digital apparatus meets all the requirements of the Canadian Interference-Causing Equipment Regulations.  
Cet appareil numérique de la Classe (B) respecte toutes les exigences du Règlement sur le matériel brouilleur du Canada.*



### **Building Efficiency**

507 E. Michigan Street, Milwaukee, WI 53202

*® Johnson Controls and PENN are registered trademarks of Johnson Controls, Inc. in the United States of America and/or other countries. All other trademarks used herein are the property of their respective owners. © Copyright 2015 by Johnson Controls, Inc. All rights reserved.*