

Installation and Operation Manual

Provides Pump Rotation,
Auxiliary Pump Activation, and
Pump Failure Alarm Control

PLL

Pump-Lead-Lag

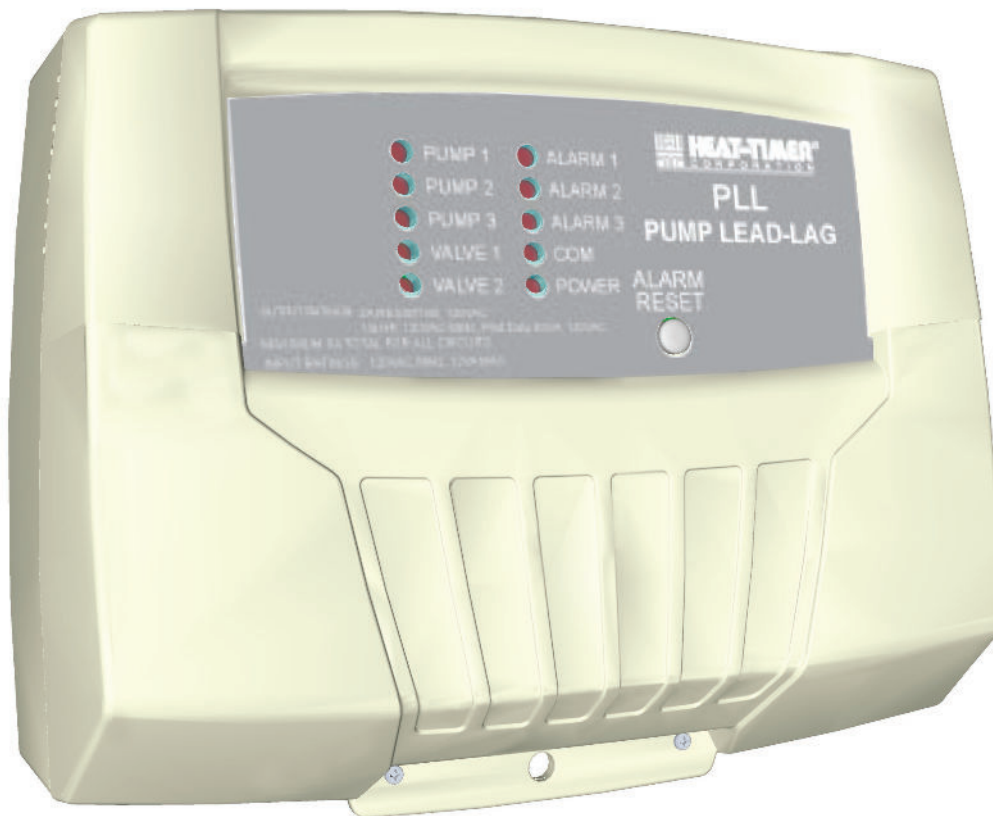

⚠ WARNING

This Heat-Timer control is strictly an operating control; it should never be used as a primary limit or safety control. All equipment must have its own certified limit and safety controls required by local codes. The installer must verify proper operation and correct any safety problems prior to the installation of this Heat-Timer control.

 **HEAT-TIMER**[®]
CORPORATION

HT# 059296-00A

CONTENTS

PLL Layout3
Overview4
Alarming4
Alarming on No-Flow4
Ending the Alarm4
Rotation options4
1-Call / 1-Flow (2-Pump Mode) or (3-Pump Mode)4
1-Call, 2-Flow (2-Pump)5
Auxiliary Pump5
2-Call, 2-Flow (3-Pump)5
Pump Delay6
3-Call, 3-Flow (3-Pump)6
Pump exercise6
Installation Steps6
Installation7
Mounting The Enclosure7
Wiring8
Wiring the Power8
Input Wiring8
Pump Call Input Wiring8
Flow Input Wiring8
Output Wiring8
Pump Output Wiring9
Valve Output Wiring9
Visual/Audio Alarm Output Wiring9
Web or EMS Alarm Output Wiring9
Dip Switches	10
LEDs	11
Button	11
Wiring and Piping Diagrams	12
2-Pump 1-Call 1-Flow Wiring	12
2-Pump 1-Call 1-Flow Piping	13
2-Pump 1-Call 2-Flow Wiring	14
2-Pump 1-Call 2-Flow Piping	15
3-Pump 1-Call 1-Flow Wiring	16
3-Pump 1-Call 1-Flow Piping	17
3-Pump 2-Call 2-Flow Wiring	18
3-Pump 2-Call 2-Flow Piping	19
3-Pump 3-Call 3-Flow Wiring	20
3-Pump 3-Call 3-Flow Piping	21
Warranty	22
Specification	23

PLL LAYOUT

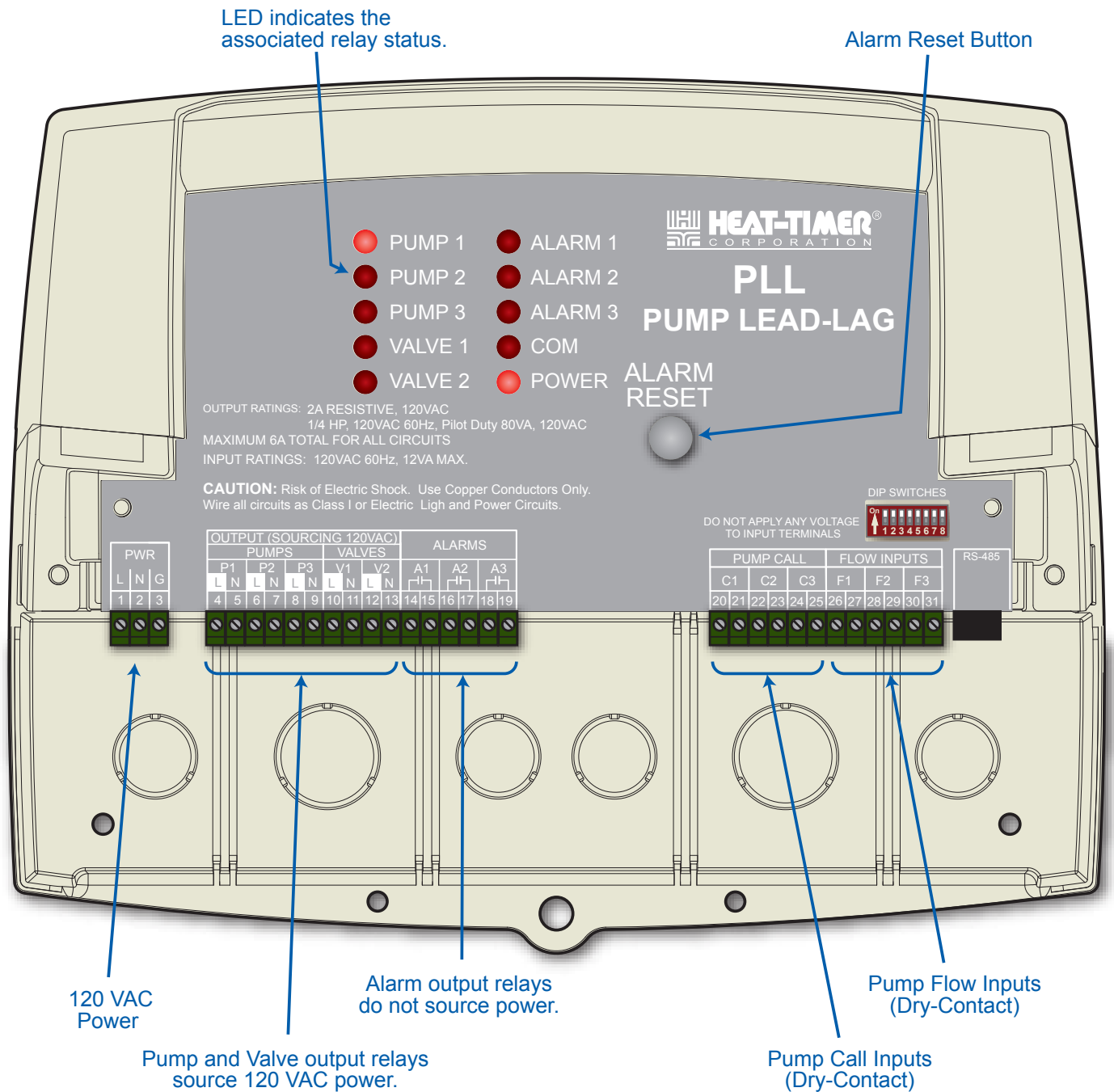

1-Call, 2-Flow (2-Pump)

- This mode is designed to rotate two system pumps in a hydronic application. It is primarily used with Variable Frequency Drive (VFD) pumps.
- The operation of this mode is similar to the 1-Call/1-Flow Mode listed previously. The only exception is that each pump will have its own flow input. That means that pump call must be connected to Pump 1 call input terminals (C1) (20 and 21). Pump 1 flow input must be connected to Flow 1 input terminals (F1) (26 and 27) and Pump 2 flow input must be connected to Flow 2 input terminals (F2) (28 and 29).

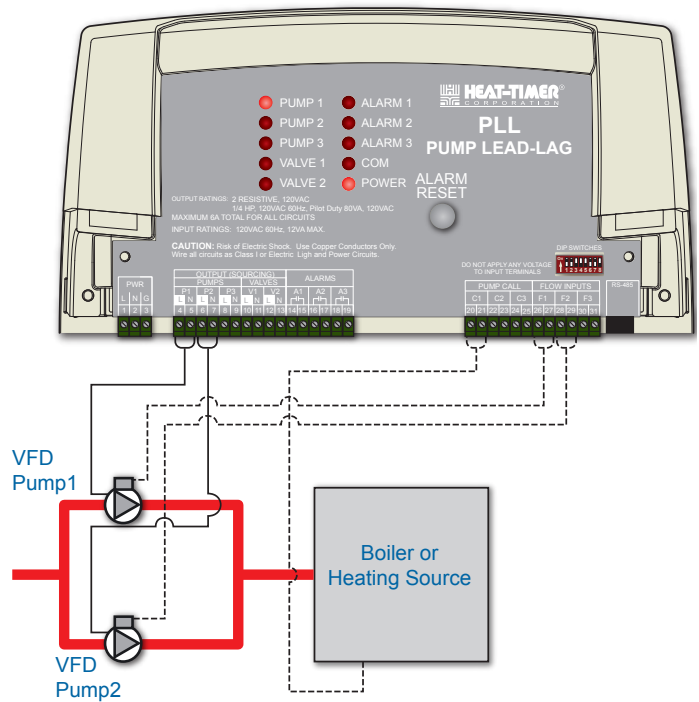

AUXILIARY PUMP

2-Call, 2-Flow (3-Pump)

- This configuration is typically used in a two-Boiler Feed application. It uses an Auxiliary pump / Pump 3 to replace any failing boiler feed pump. It does that by turning on a normally closed solenoid valve to direct the flow from the failing pump to the auxiliary pump.
- No rotation is available in this mode. The PLL control operates a single pump per boiler.
- A maximum of two boiler pumps can be connected to a single PLL.
- If any of the boiler pumps fail to provide proof-of flow in 30 seconds, the PLL will switch its operation to the Auxiliary pump / Pump 3 (P3).
- The valve outputs are used to operate solenoid valves to switch the system flow from the failed pump to the Auxiliary pump / Pump 3 (P3). Valve 1 output (V1) is turned on when Pump 1 fails and goes into alarm. Valve 2 output (V2) is turned on when Pump 2 fails and goes into alarm. See "Valve Output Wiring" on page 9..
- If a pump fails, the PLL will turn it off and will turn on its Alarm output, its Valve output, and the Auxiliary pump / Pump 3 (P3) output. In addition, it will blink its Alarm LED.
- If the second pump fails for over 30 seconds while the first pump is in alarm, the PLL will turn off the 2nd pump and turn on its relevant solenoid valve and Alarm LED. In this case, the Auxiliary pump / Pump 3 (P3) replaces both primary pumps until the situation is rectified and the Manual Reset button is pressed.

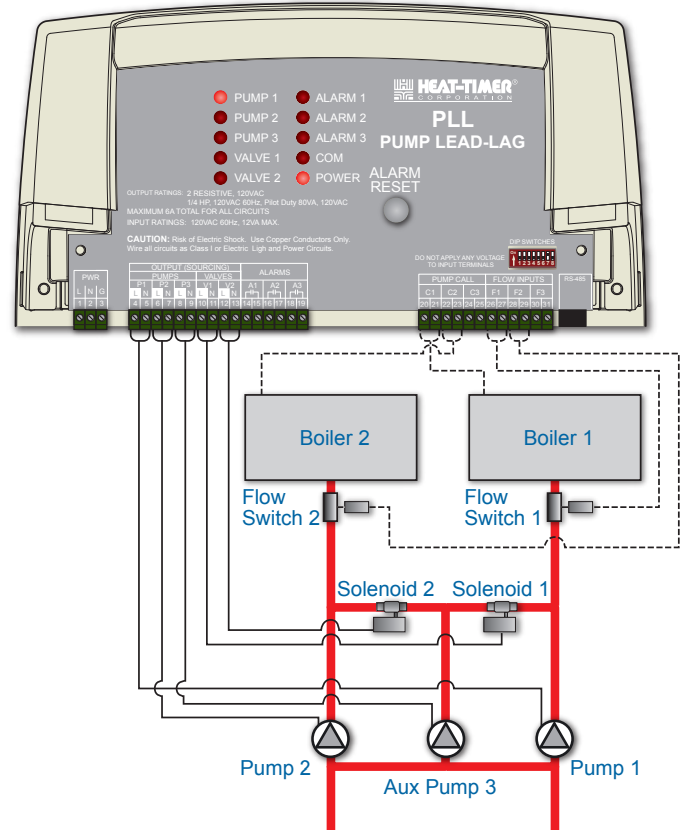

PUMP DELAY

3-Call, 3-Flow (3-Pump)

- This configuration is typically used in one, two, or three boiler pump applications to offer pump delay and alarming. The PLL control operates a single pump per boiler.
- Each of the pump calls will use a different pump call input (C1, C2, and C3).
- Also, each of the pump flows will use the respective pump flow input (F1, F2, and F3).
- No rotation is available in this mode.
- If a pump failed to provide proof-of-flow for over 30 seconds, the PLL will turn that pump output off and turn on its alarm.

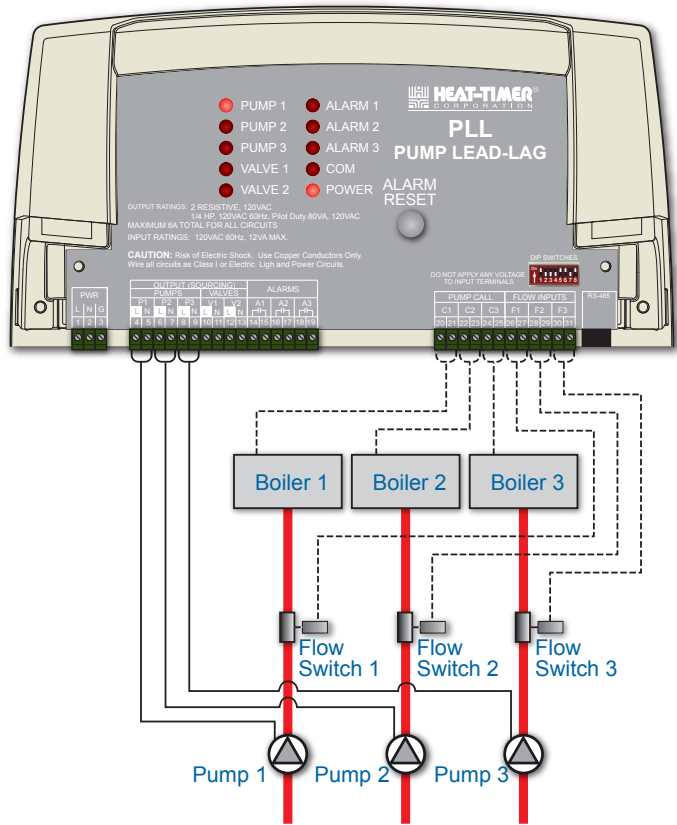

PUMP EXERCISE

- This option is recommended for all pumps as it helps protect the pumps from locking due to sediment deposit and rust in the system. It proves very beneficial to wet rotor pumps as it helps lubricate their seals.
- When this feature is enabled, The PLL exercises any pump that did not run for a week. The exercise period is 10 seconds.

INSTALLATION STEPS

Follow these steps to make sure that all aspects of the system installation are done:

1. Mount the PLL control. See "Mounting The Enclosure" on page 7.
2. Wire the PLL control to the power, the pumps, flow inputs, valves, and the alarms. See "Wiring" on page 8.
3. Set the dip switches to match your application. See "Dip Switches" on page 10..
4. Power the control.

INSTALLATION

MOUNTING THE ENCLOSURE

- Select a location near the equipment to be controlled.
- The surface should be flat and sufficiently wide and strong to hold the PLL.
- Keep the control away from extreme heat, cold, or humidity. Ambient operating temperature is from 20 to 120°F.
- Remove the Enclosure Wiring Cover from the control enclosure by removing the two bottom screws.
- Remove the Enclosure Display Module by removing its Mounting Screws.
- Screw the Enclosure Base to the surface through the upper and lower mounting holes on the back of the enclosure.
- Replace the Enclosure Display Module and its Mounting Screws.
- Do not replace the Enclosure Wiring Cover until all wiring is done.
- When purchasing a padlock for the enclosure, the maximum shank diameter should not exceed 1/4"

Warning
The PLL is an operating control only not a safety control. It is the responsibility of the installer to verify that all the safety and limits required by code are working properly before and after the PLL is installed.

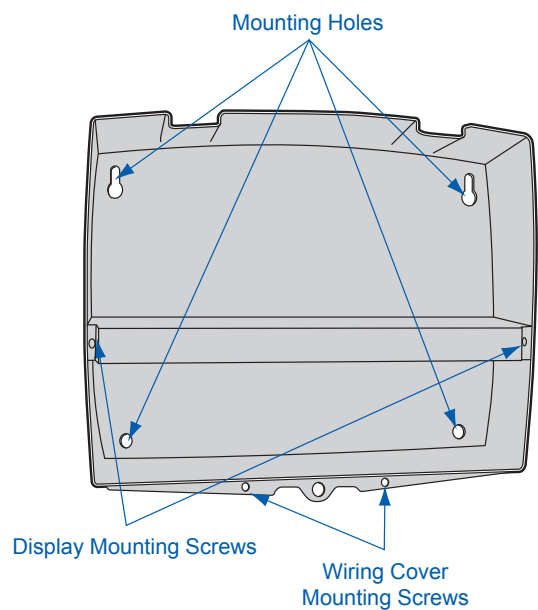
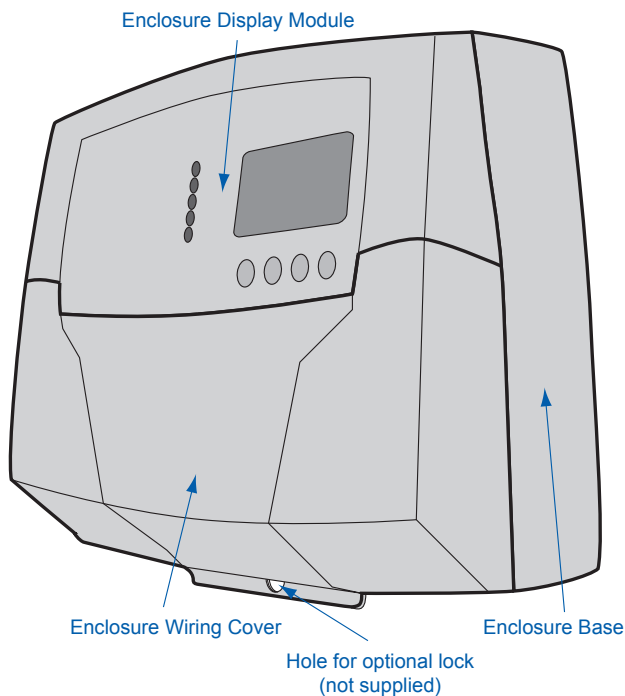

WIRING

⚠ Warning

Class 1 voltage wiring (low voltage) must use a different knockout and conduit from any Class 2 voltage wiring (high voltage).

WIRING THE POWER

- Bring the power wires through one of the bottom knockouts of the enclosure.
- Attach 120V 60 Hz wires to their respective Line, Neutral, and Ground terminals.
- Heat-Timer recommends the installation of a Surge Suppressor and a Power Switch before the Power Line connection for safety and ease of service.

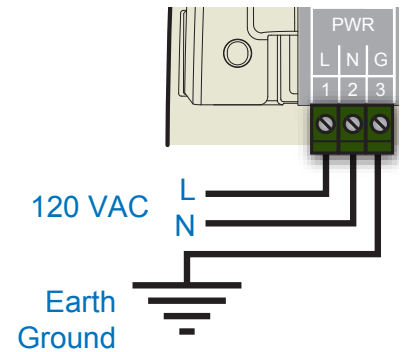

INPUT WIRING

⚠ Warning

All of the PLL inputs are dry-contact only. DO NOT APPLY POWER TO ANY INPUT as this may damage the control and void its warranty.

Pump Call Input Wiring

Pump Call (C1 Terminal 20 and 21), (C2 Terminal 22 and 23), (C3 Terminal 24 and 25)

- Depending on the mode selected, the PLL may require the use of one, two, or three Pump Call inputs. See "Dip Switches" on page 10.
- Wire each Pump input into the corresponding input terminals of the PLL. See "Overview" on page 4.

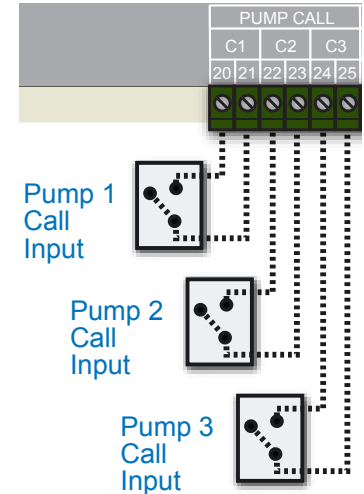

Flow Input Wiring

Pump Flow (F1 Terminal 26 and 27), (F2 Terminal 28 and 29), (F3 Terminal 30 and 31)

- Depending on the mode selected, the PLL may require the use of one, two, or three flow inputs. See "Overview" on page 4.
- Wire each Flow input to the corresponding input terminals of the PLL.
- If a pump fails to provide a flow signal for over 30 seconds, by shorting the proper flow input terminal, the PLL will turn off the failing pump's output and LED and turn on the its pump alarm output and LED.
- If the mode selected rotates the lead pump or offers an auxiliary pump operation, the failed pump alarm will cause the lead pump to go the next available pump or the auxiliary pump.

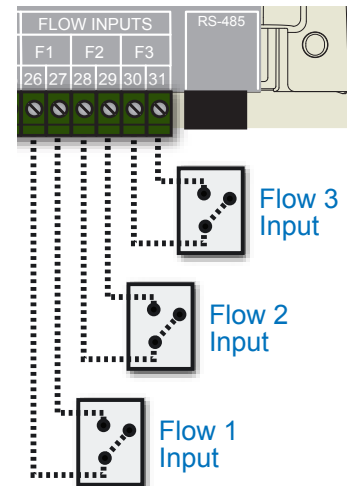

⚠ ALERT

If no flow switch is used, use a jumper on the flow input terminals. (Heat-Timer recommends using a flow switch for better system response and operation.)

OUTPUT WIRING

- The PLL provides 120 VAC 60Hz power to the pump and solenoid valve output relays. Each relay can power up to 1/4 HP pump (120 VAC 60 Hz) or 80 VA Solenoid Valves (120 VAC 60Hz).
- The PLL does not provide power to the alarm output relays. A separate power source must supply the power to the alarm. In this case, the alarm relays act as a power switches.

⚠ Warning

Each of the Pump and Solenoid valve outputs source 120 VAC. If the pump used require more than 1/4 HP or if the solenoid used require more than 80 VA of 120 VAC, use a relay or a starter to prevent PLL damage.

Pump Output Wiring

- Before wiring the pumps, decide on the function of each of the pumps based on the mode selected.
- Each of the PLL pump outputs sources power to operate a pump up to ¼ HP (120 VAC, 60Hz).
- If the pump requires more power than what the PLL can output, use a pump starter or an external higher output power relay.
- Wire the Pump output terminals to the pumps or pump starters.

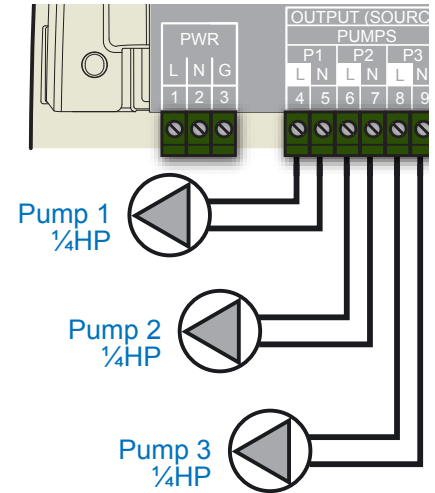

Valve Output Wiring

- Valve outputs function only in the 2-Call 2-Flow 3-Pump Mode. See "2-Call, 2-Flow (3-Pump)" on page 5.
- The valve outputs are used to operate normally closed (N. C.) solenoid valves to switch the system flow from the failed pump to the Auxiliary pump (Pump 3). Valve 1 output (V1) is turned on when Pump 1 fails and goes into alarm. Valve 2 output (V2) is turned on when Pump 2 fails and goes into alarm.
- The valve outputs source 120 VAC 60Hz power. Each output can operate an 80 VA solenoid valve.
- If the valve requires more power than what the PLL can output, use an external higher output power relay.
- Connect Valve 1 (V1) and Valve 2 (V2) outputs to their respective solenoid valves.

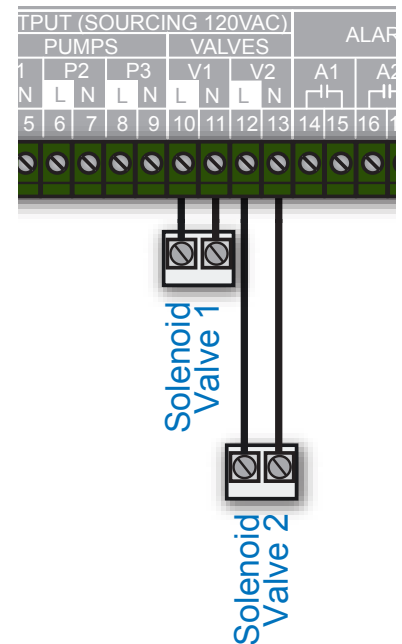

Visual/Audio Alarm Output Wiring

- The PLL has 3 alarm outputs, one for each of the pump outputs. An Alarm output is triggered when its pump fails to provide proof-of-flow in 30 seconds.
- The Alarm outputs do not source any power. A separate power source must be supplied. Each set of contacts is capable of switching 1A Inductive, 6A Resistive at 120 VAC.
- Connect the Alarm outputs to an alarm. The Heat-Timer Vis-U-Larm (HT #925011-00) is a visual-audio alarm that is designed to work with the PLL. It has both a Red Alarm light in addition to a sound alarm.
- All Alarm outputs can be wired to use the same alarm unit as per the graph.

Web or EMS Alarm Output Wiring



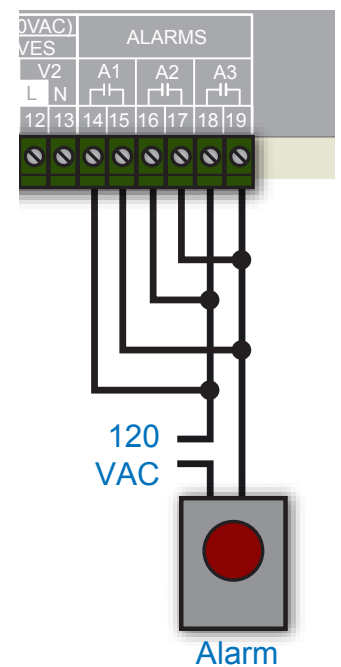











- The Alarm outputs can be used to trigger Internet alarms using a Heat-Timer Internet-ready Platinum control. It can also be used to trigger a BMS alarm.
- Connect the Alarm output to any of the Aux Temp or Mini-MIG inputs on an Internet-ready Heat-Timer Platinum heating control.
- Web alarms allows the user of a Platinum heating control to receive the alarm notification on the web, by E-Mail, or a cellular phone text message. See Internet Control Manuals.
- An BMS alarm output allows an BMS system to receive an alarm notification.



HT# 059296-00A

DIP SWITCHES

The PLL control is designed to operate pumps in multiple modes. Each mode can be activated by adjusting the dip switches.

Mode	Pumps	Mode Dip Switch Settings	Pump Rotation Dip Switches	Pump Exercise Switch
Inputs	Outputs			
2-Pump Modes				
1 Call - 1 Flow	2 Pumps			
C1 F1	P1, P2	Dip1= On Dip2= Off	Per Call Rotation = Dip4= On, Dip5=Off, Dip6=Off 1 Day Rotation = Dip4= Off, Dip5=On, Dip6=Off 7 Day Rotation = Dip4= Off, Dip5=Off, Dip6=On	Exercise On = Dip7= On Exercise Off = Dip7= Off
1 Call - 2 Flow	2 Pumps			
C1 F1, F2	P1, P2	Dip1= On Dip2= On	Per Call Rotation = Dip4= On, Dip5=Off, Dip6=Off 1 Day Rotation = Dip4= Off, Dip5=On, Dip6=Off 7 Day Rotation = Dip4= Off, Dip5=Off, Dip6=On	Exercise On = Dip7= On Exercise Off = Dip7= Off
3-Pump Modes				
1 Call - 1 Flow	3 Pumps			
C1 F1	P1, P2, P3	Dip1= Off Dip2= Off Dip3= On	Per Call Rotation = Dip4= On, Dip5=Off, Dip6=Off 1 Day Rotation = Dip4= Off, Dip5=On, Dip6=Off 7 Day Rotation = Dip4= Off, Dip5=Off, Dip6=On	Exercise On = Dip7= On Exercise Off = Dip7= Off
2 Call - 2 Flow	3 Pumps		No Rotation Available	
C1, C2 F1, F2	P1, P2, P3	Dip1= Off Dip2= Off Dip3= Off		Exercise On = Dip7= On Exercise Off = Dip7= Off
3 Call - 3 Flow without Delay	3 Pumps		No Rotation Available	
C1, C2, C3 F1, F2, F3	P1, P2, P3	Dip1= Off Dip2= On Dip3= On Dip4= Off		Exercise On = Dip7= On Exercise Off = Dip7= Off
3 Call - 3 Flow with 6 minute Delay	3 Pumps		No Rotation Available	
C1, C2, C3 F1, F2, F3	P1, P2, P3	Dip1= Off Dip2= On Dip3= On Dip4= Off		Exercise On = Dip7= On Exercise Off = Dip7= Off

HT# 059296-00A

LEDS

Pump and Valve LEDs

- Each LED is assigned to its respective output operation. When a pump or a valve output is active, its LED is lit.

Power LED

- The lower right LED is used to indicate the control power.

Alarm LEDs

- Alarm LEDs blink when their respective alarm output is active. The blinking helps alert the use to their status from a far distance. See "Overview" on page 4.

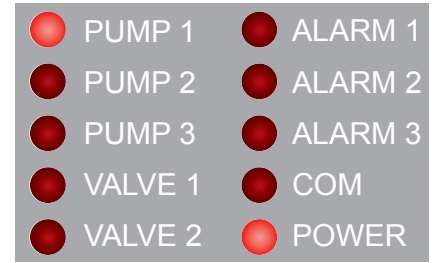

BUTTON

- The PLL has only one button (Alarm Reset). The button is used to reset the alarm status of any failed pump.
- When a pump fails to provide proof-of-flow within 30 seconds, its alarm output is activated. The PLL will stop this pump from running and will not make it available until the Alarm Reset button is pressed. See "Alarming" on page 4.



TROUBLESHOOTING

Power LED Not On

Check the power wiring to the PLL using a voltmeter set to AC. The PLL requires 120 VAC power source.

Pump Output Relays do not Turn On

To test any of the pump output relays, energize the relay by first setting the control to 3-Call 3-Flow mode. See "Dip Switches" on page 10. Then, initiate a call for the pump in question by shorting its (C) and (F) input terminals. Then test for continuity across the output terminals using a continuity meter. If continuity exists, the relay is functioning properly. Otherwise, if no continuity exists, check the fuse on the back of the Enclosure Display Module. The fuse is 20 mm 5 amp may need to be replaced.

Valve Output Relays do not Turn On

To test a valve output, the PLL dip switches must be set to 3- Pump 2-Call 2-Flow mode. See "Dip Switches" on page 10. Then, initiate a call for the respective pump (C) and wait 30 seconds for the alarm output and valve output to be activated. Then test for continuity across the output terminals using a continuity meter. If continuity exists, the relay is functioning properly. Otherwise, if no continuity exists, check the fuse on the back of the Enclosure Display Module. The fuse is 20 mm 5 amp may need to be replaced.

Alarm Output Relays do not Turn On

To test any of the alarm output relays, energize the respective pump relay by first setting the control to 3-Call 3-Flow mode. See "Dip Switches" on page 10. Then, initiate a call for the respective pump (C) and wait 30 seconds for the alarm output to be activated. Then test for continuity across the output terminals using a continuity meter. If continuity exists, the relay is functioning properly. Otherwise, if no continuity exists, check the fuse on the back of the Enclosure Display Module. The fuse is 20 mm 5 amp may need to be replaced.

WIRING AND PIPING DIAGRAMS

2-PUMP 1-CALL 1-FLOW WIRING

ELECTRIC

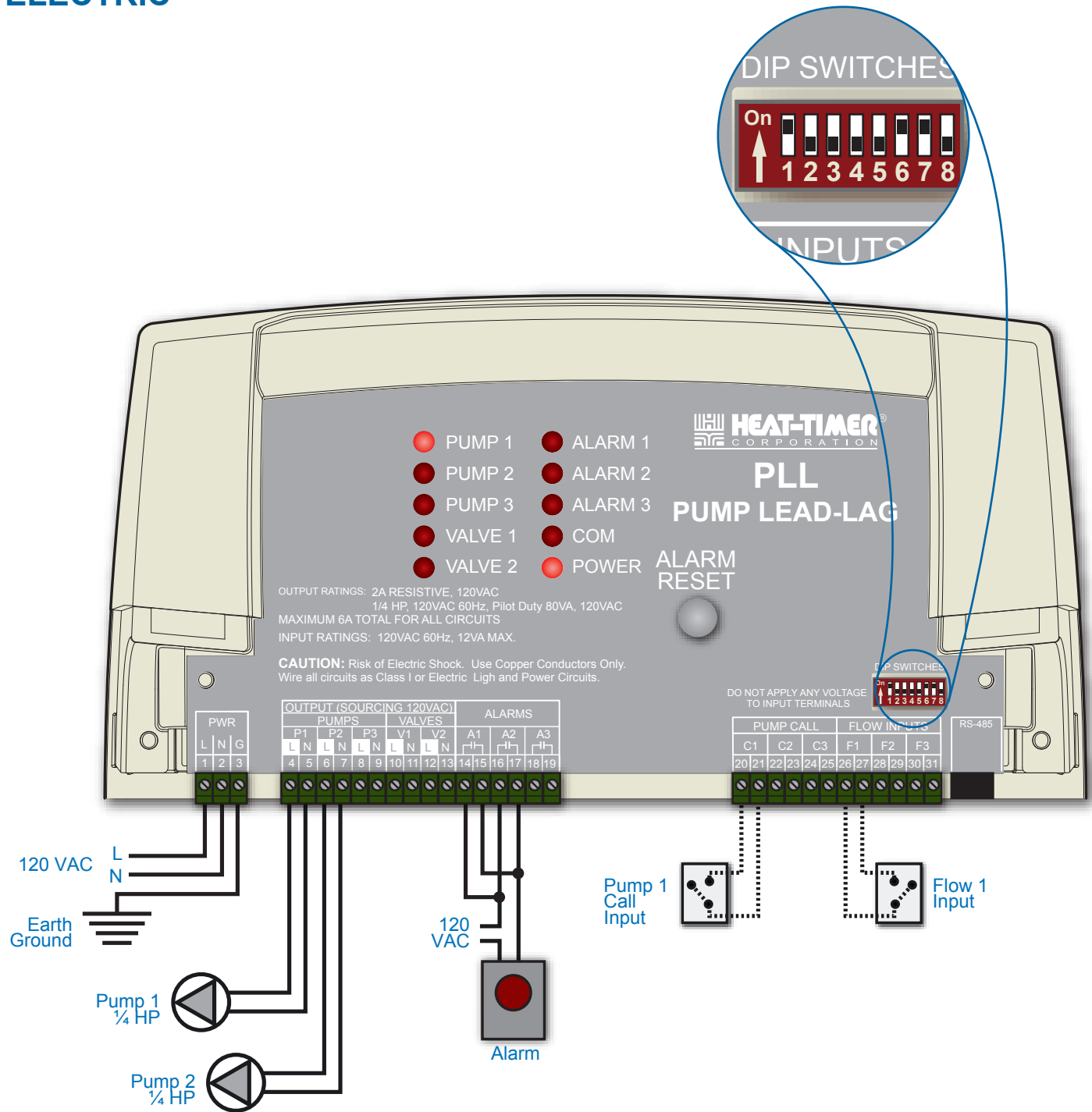

Warning
 Inputs are dry-contact. No voltage should be placed across the input terminals.
 Output sourcing terminals provide 120 VAC. See output rating prior to connecting equipment to avoid output damage.

DIP Switch Settings:
 Dip1 = ON (2-Pump Mode)
 Dip2 = OFF (1-Call + 1-Flow Mode)
 Dip4 - 6 = Choose Rotation option

HT# 059296-00A

2-PUMP 1-CALL 1-FLOW PIPING

MECHANICAL

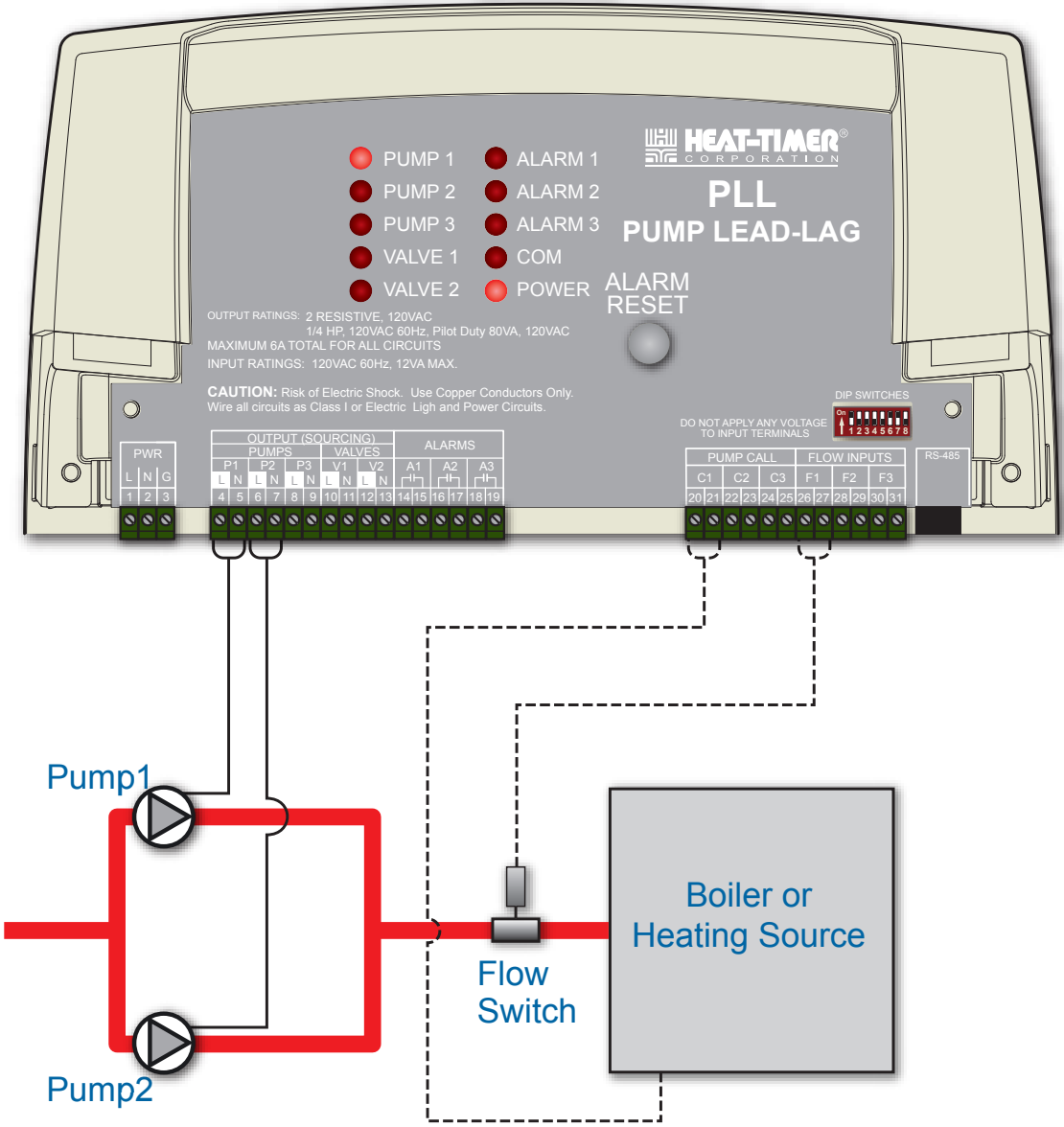

⚠ ALERT

Heat-Timer is aware that each installation is unique. Thus, Heat-Timer is not responsible for any installation related to any electrical or plumbing diagram generated by Heat-Timer. The provided illustrations are to demonstrate Heat-Timer's control operating concept only.

HT# 059296-00A

2-PUMP 1-CALL 2-FLOW WIRING

ELECTRIC

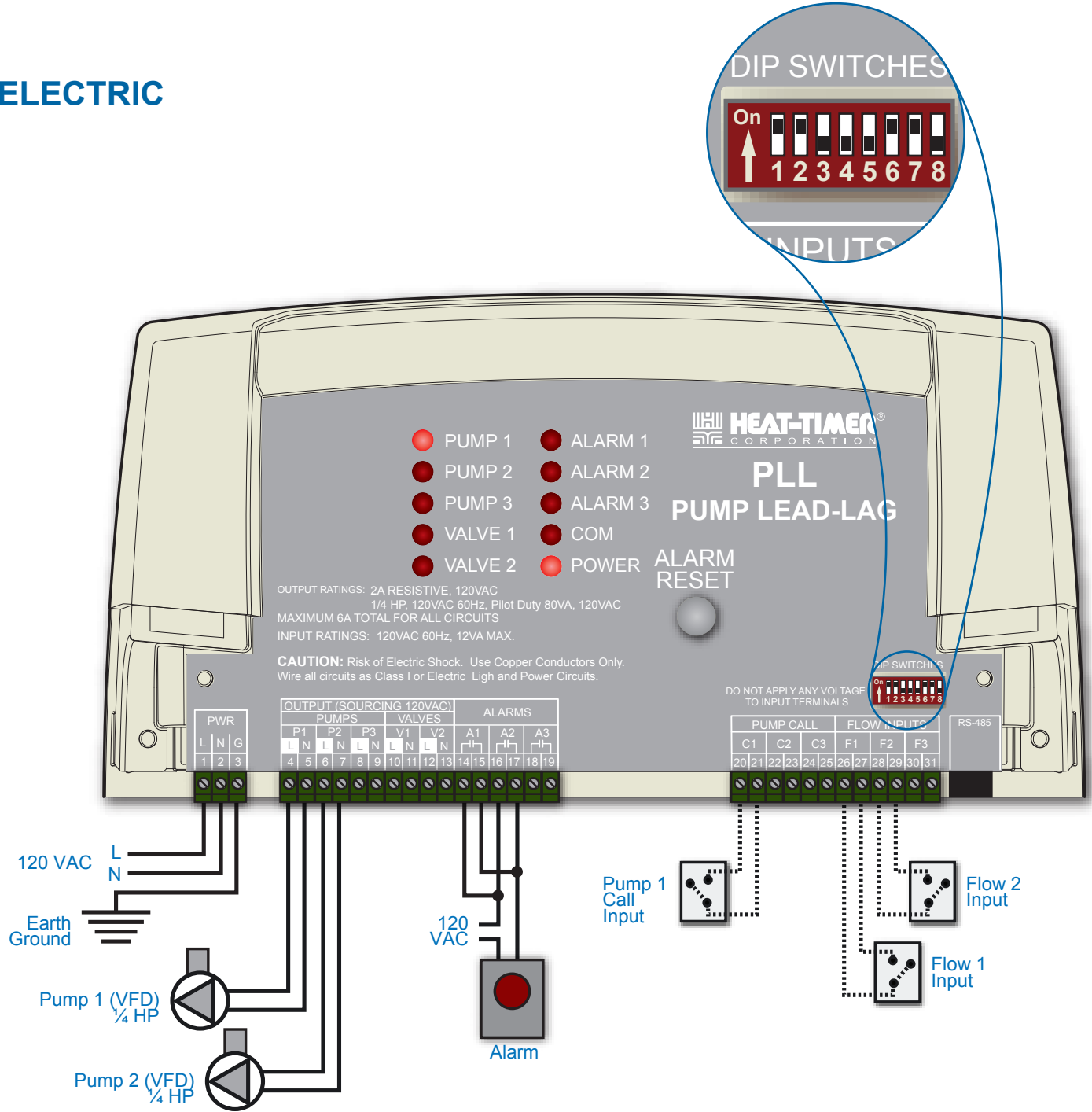

- DIP Switch Settings:**
- Dip1 = ON (2-Pump Mode)
 - Dip2 = ON (1-Call + 2-Flow Mode)
 - Dip4 - 6 = Choose Rotation option

Warning

Inputs are dry-contact. No voltage should be placed across the input terminals.

Output sourcing terminals provide 120 VAC. See output rating prior to connecting equipment to avoid output damage.

HT# 059296-00A

2-PUMP 1-CALL 2-FLOW PIPING

MECHANICAL

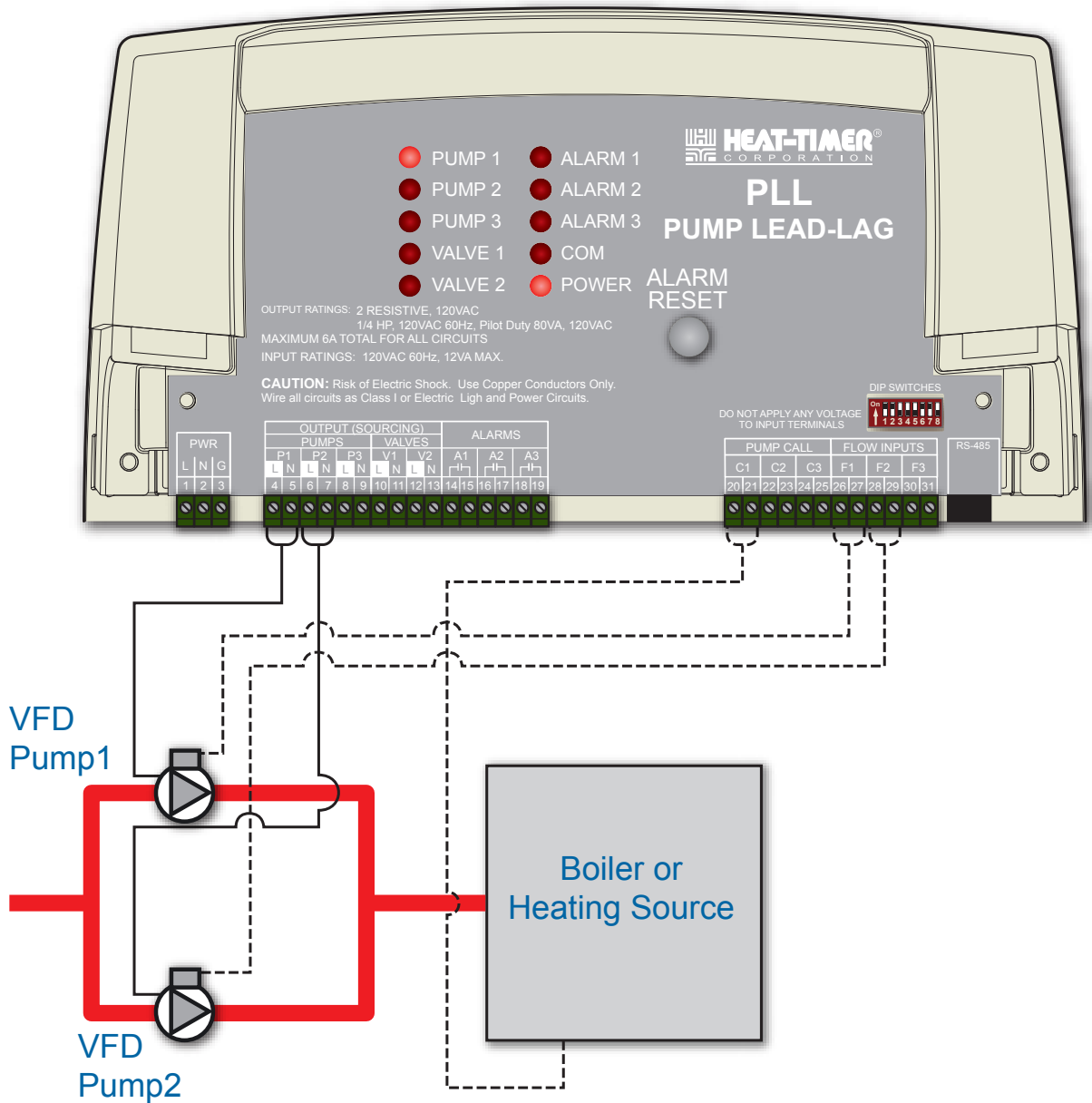

⚠ ALERT
 Heat-Timer is aware that each installation is unique. Thus, Heat-Timer is not responsible for any installation related to any electrical or plumbing diagram generated by Heat-Timer. The provided illustrations are to demonstrate Heat-Timer's control operating concept only.

HT# 059296-00A

3-PUMP 1-CALL 1-FLOW WIRING

ELECTRIC

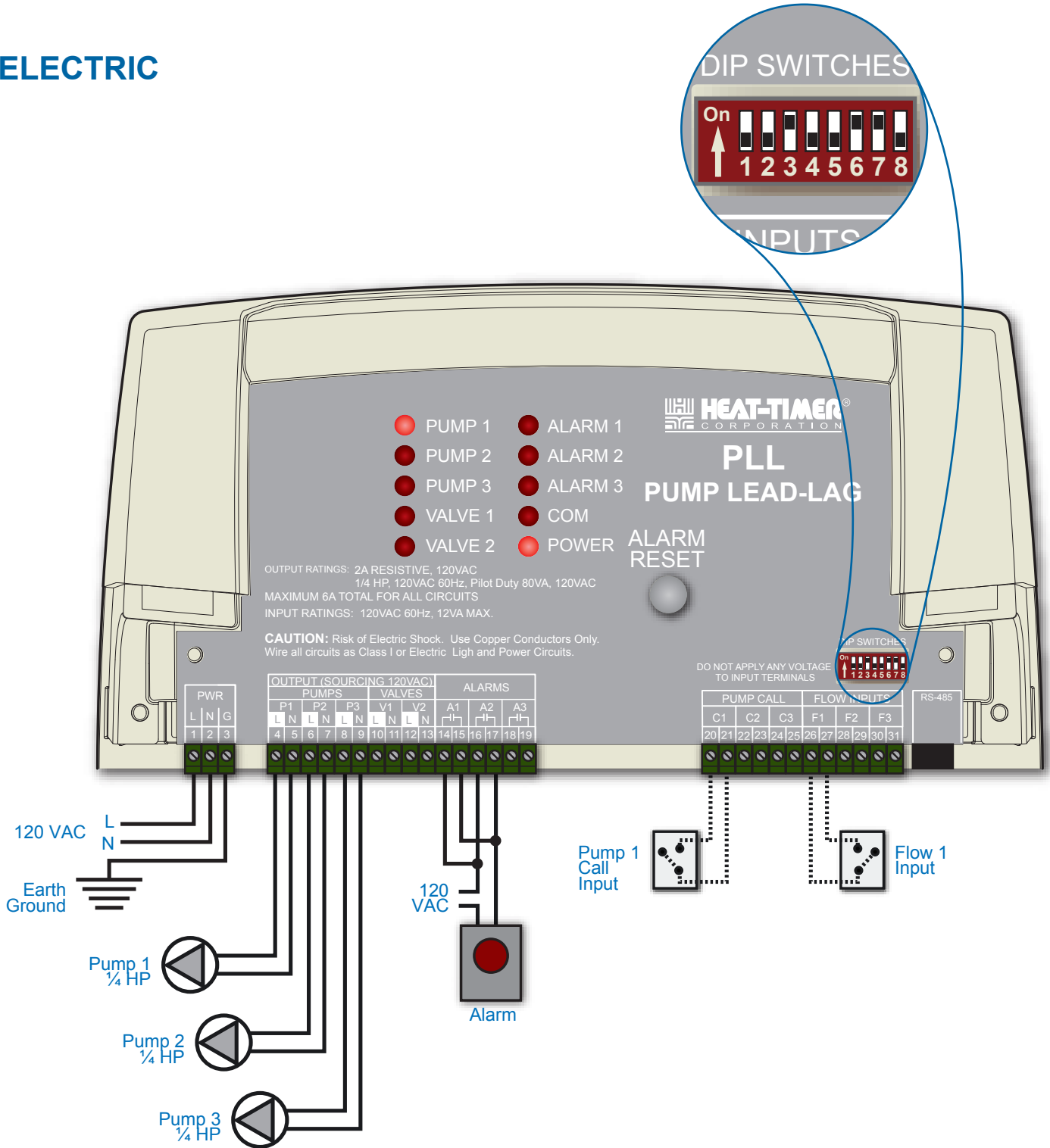

⚠ Warning

Inputs are dry-contact. No voltage should be placed across the input terminals.
 Output sourcing terminals provide 120 VAC. See output rating prior to connecting equipment to avoid output damage.

DIP Switch Settings:

- Dip1 = OFF (3-Pump Mode)
- Dip3 = ON (1-Call + 1-Flow Mode)
- Dip4 - 6 = Choose Rotation option

3-PUMP 1-CALL 1-FLOW PIPING

MECHANICAL

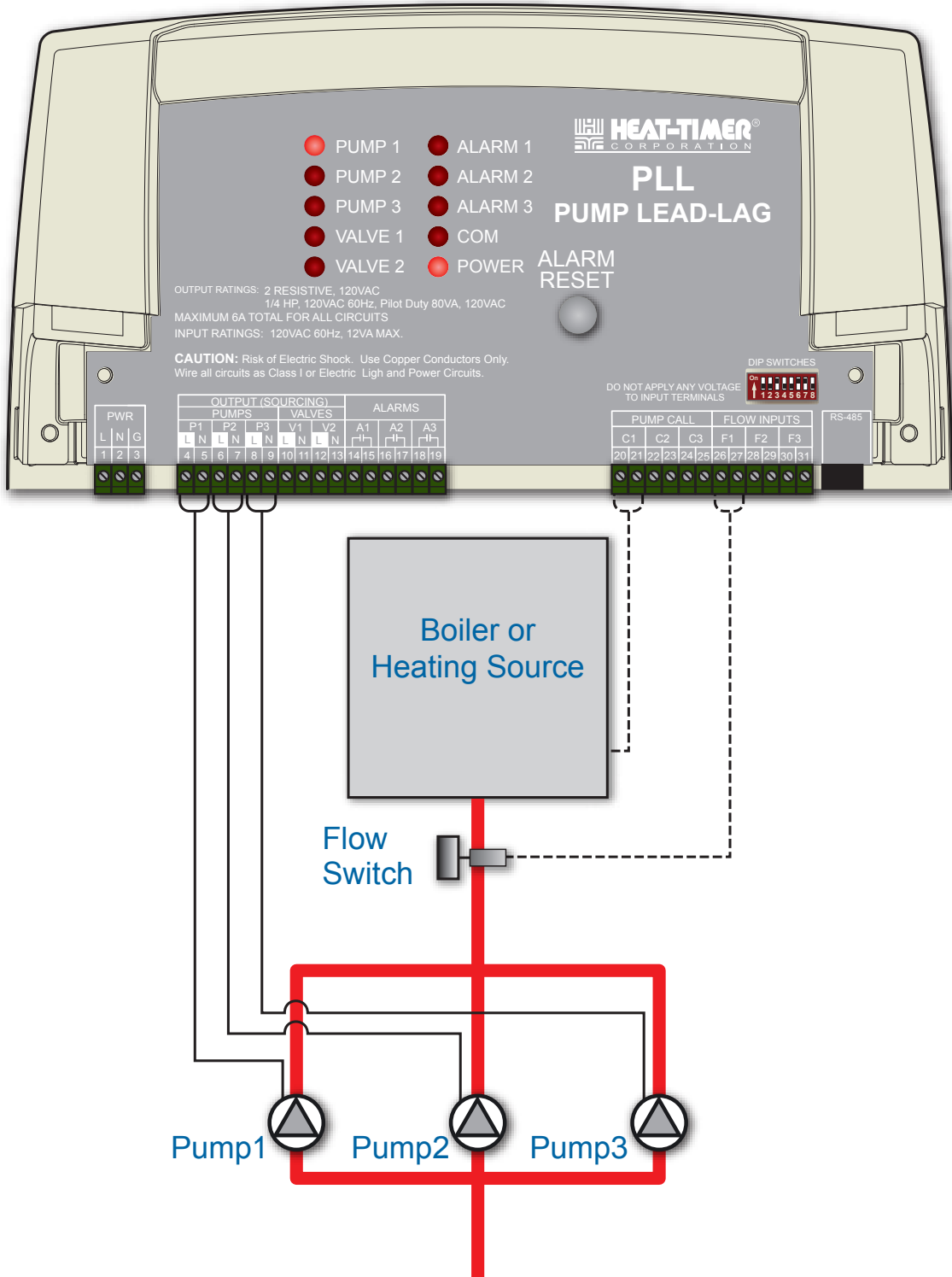

⚠ ALERT
 Heat-Timer is aware that each installation is unique. Thus, Heat-Timer is not responsible for any installation related to any electrical or plumbing diagram generated by Heat-Timer. The provided illustrations are to demonstrate Heat-Timer's control operating concept only.

HT# 059296-00A

3-PUMP 2-CALL 2-FLOW WIRING

ELECTRIC

Warning
 Inputs are dry-contact. No voltage should be placed across the input terminals.
 Output sourcing terminals provide 120 VAC. See output rating prior to connecting equipment to avoid output damage.

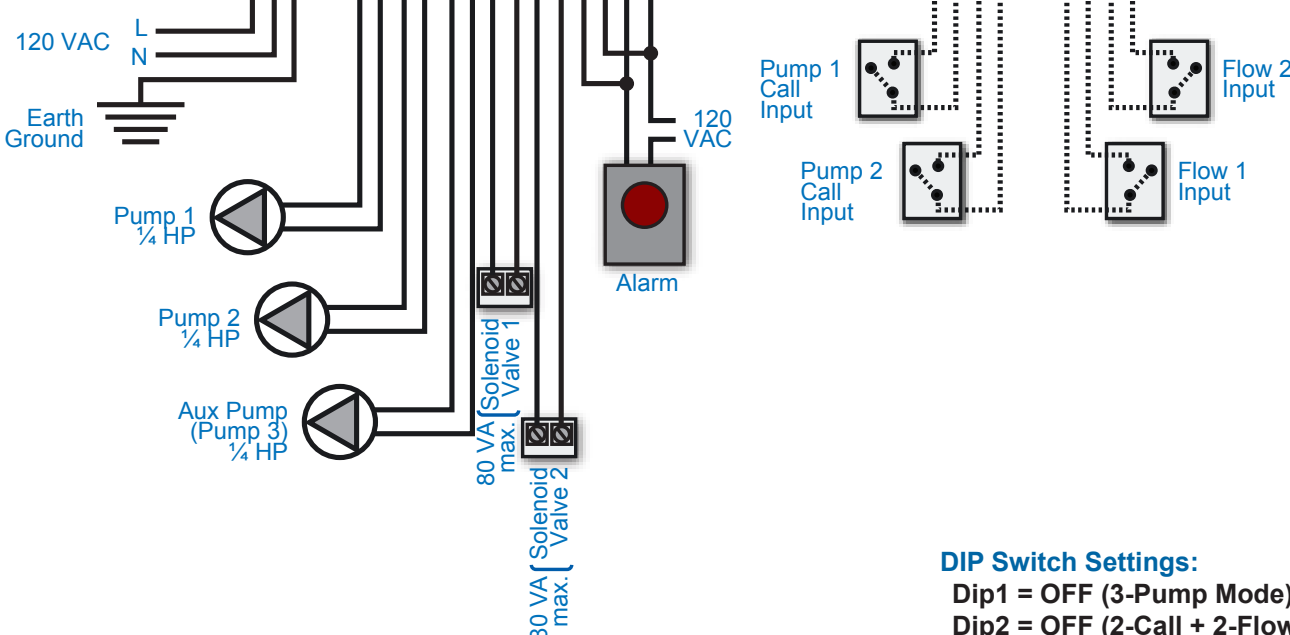
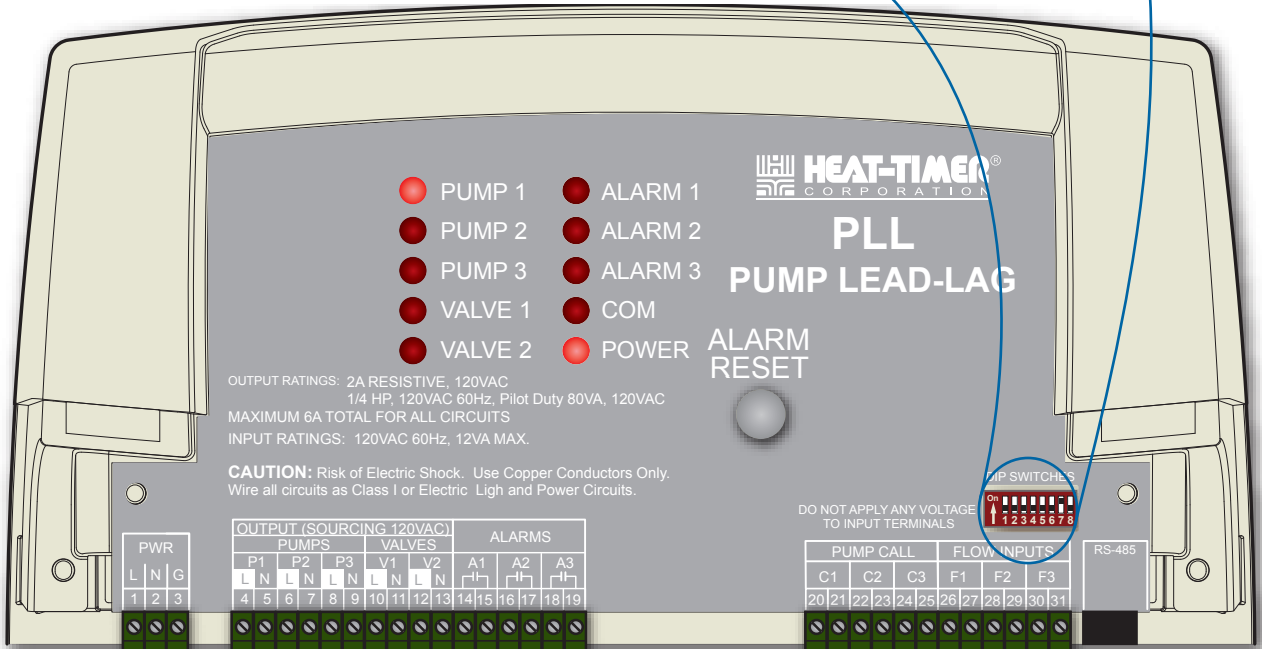
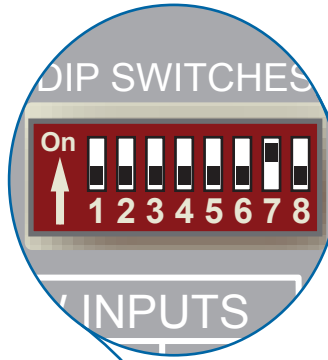

DIP Switch Settings:
 Dip1 = OFF (3-Pump Mode)
 Dip2 = OFF (2-Call + 2-Flow Mode)

HT# 059296-00A

3-PUMP 2-CALL 2-FLOW PIPING

MECHANICAL

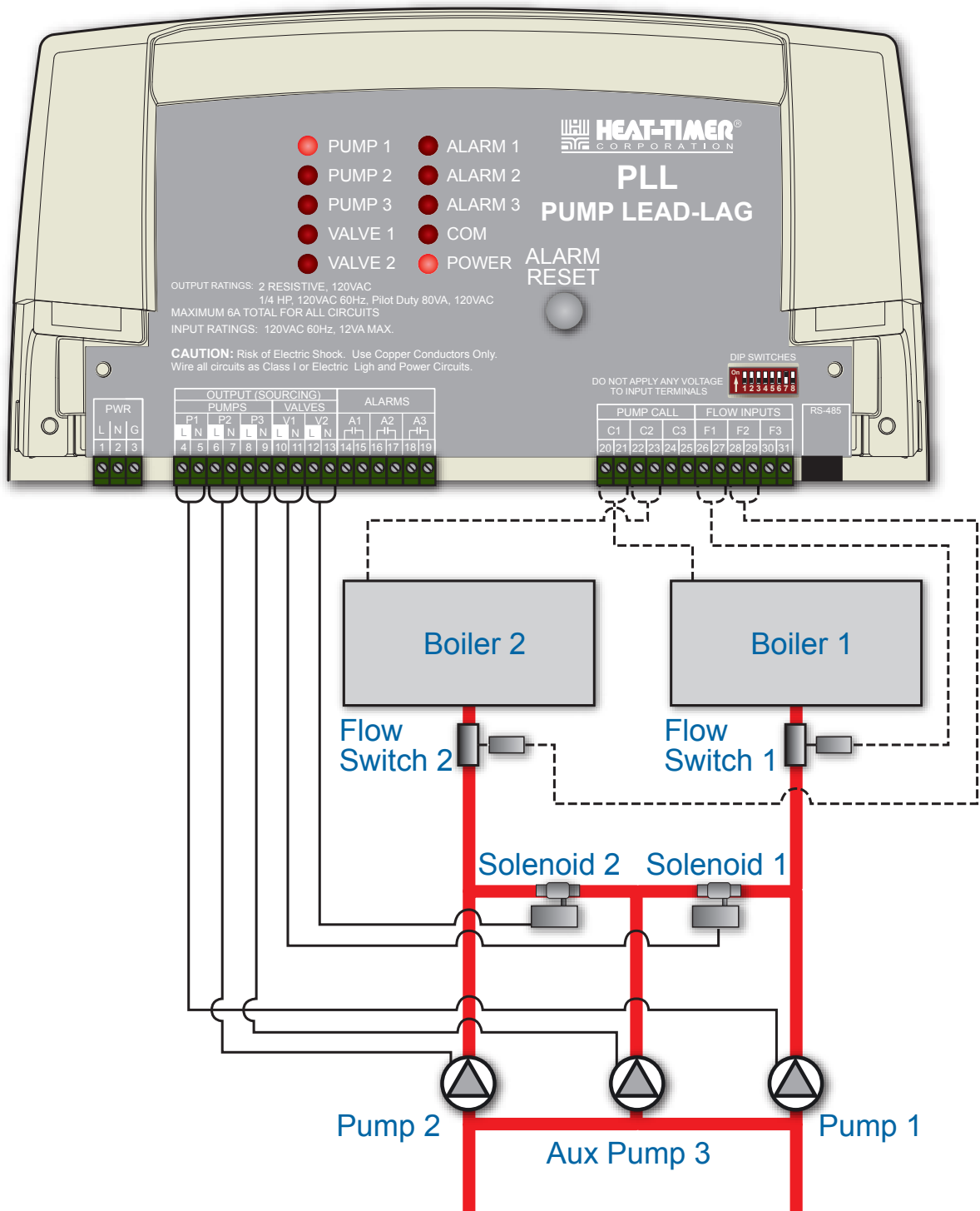

⚠ ALERT
 Heat-Timer is aware that each installation is unique. Thus, Heat-Timer is not responsible for any installation related to any electrical or plumbing diagram generated by Heat-Timer. The provided illustrations are to demonstrate Heat-Timer's control operating concept only.

HT# 059296-00A

3-PUMP 3-CALL 3-FLOW WIRING

Without Delay

ELECTRIC

With 6 Minute Delay

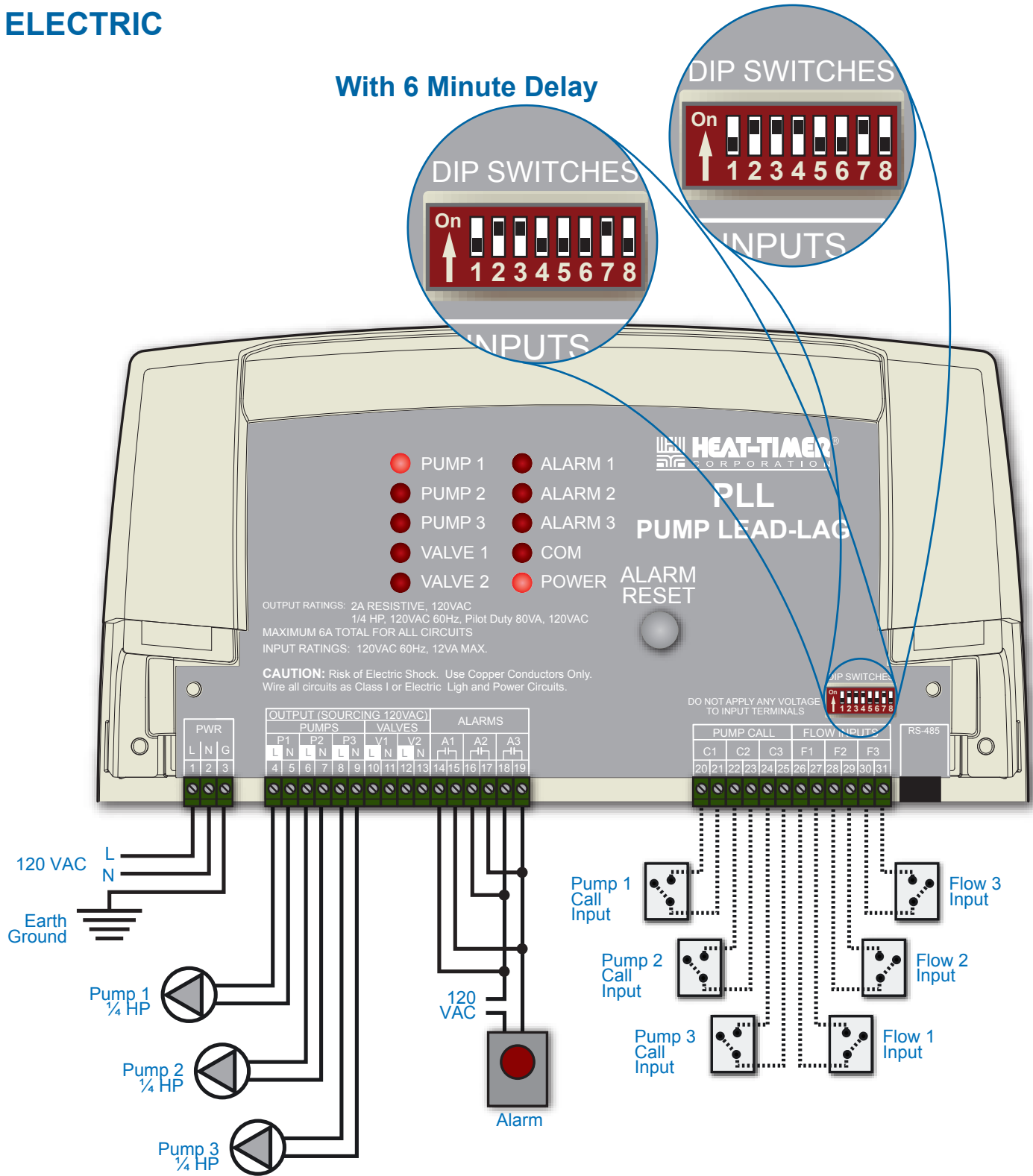

DIP Switch Settings:

- Dip1 = OFF (3-Pump Mode)
- Dip2 = ON (3-Call + 3-Flow Mode)
- Dip3 = ON
- Dip4 = OFF (6 Minute Delay) or Dip4=ON (No Delay)

3-PUMP 3-CALL 3-FLOW PIPING

MECHANICAL

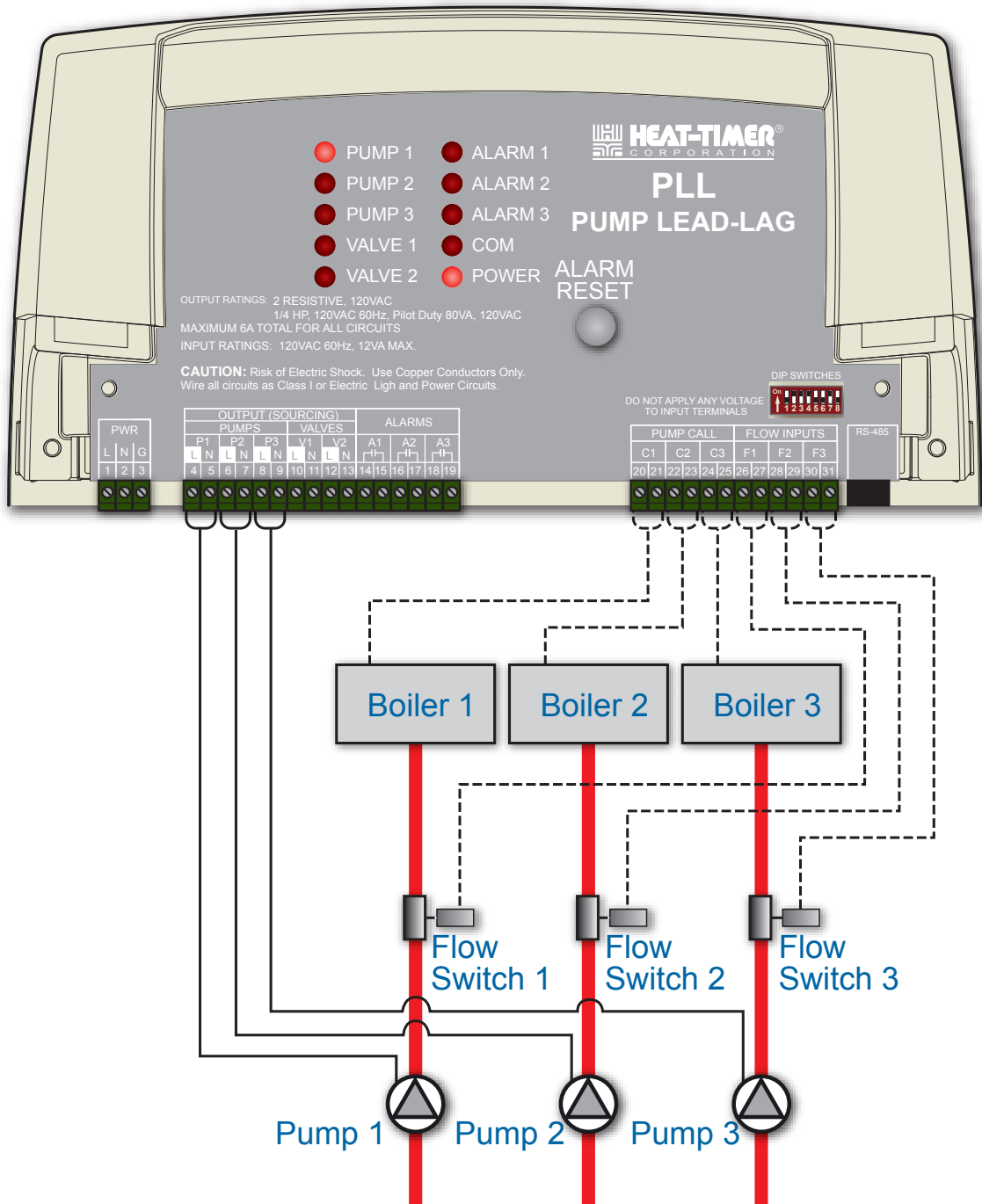

⚠ ALERT
 Heat-Timer is aware that each installation is unique. Thus, Heat-Timer is not responsible for any installation related to any electrical or plumbing diagram generated by Heat-Timer. The provided illustrations are to demonstrate Heat-Timer's control operating concept only.

HT# 059296-00A

WARRANTY

WARRANTIES AND LIMITATIONS OF LIABILITY AND DAMAGE: Heat-Timer Corporation warrants that it will replace, or at its option, repair any Heat-Timer Corporation manufactured product or part thereof which is found to be defective in material workmanship within one year from the date of installation only if the warranty registration has been properly filled out and returned within 30 days of the date of installation. Damages to the product or part thereof due to misuse, abuse, improper installation by others or caused by power failure, power surges, fire, flood or lightning are not covered by this warranty. Any service, repairs, modifications or alterations to the product not expressly authorized by Heat-Timer Corporation will invalidate the warranty. Batteries are not included in this warranty. This warranty applies only to the original user and is not assignable or transferable. Heat-Timer Corporation shall not be responsible for any maladjustments of any control installed by Heat-Timer Corporation. It is the users responsibility to adjust the settings of the control to provide the proper amount of heat or cooling required in the premises and for proper operation of the heating or cooling system. Heat-Timer Corporation shall not be required to make any changes to any building systems, including but not limited to the heating system, boilers or electrical power system, that is required for proper operation of any controls or other equipment installed by Heat-Timer Corporation or any contractor. Third Party products and services are not covered by this Heat-Timer Corporation warranty and Heat-Timer Corporation makes no representations or warranties on behalf of such third parties. Any warranty on such products or services is from the supplier, manufacturer, or licensor of the product or service. See separate Terms and Conditions of Internet Control Management System (“ICMS”) services, including warranties and limitations of liability and damages, for ICMS services.

THE FOREGOING IS IN LIEU OF ALL OTHER WARRANTIES, EXPRESS OR IMPLIED AND HEAT-TIMER CORPORATION SPECIFICALLY DISCLAIMS ANY AND ALL WARRANTIES OF MERCHANTABILITY FOR A PARTICULAR PURPOSE. UNDER NO CIRCUMSTANCES SHALL HEAT-TIMER CORPORATION, ITS AUTHORIZED REPRESENTATIVES, AFFILIATED OR SUBSIDIARY COMPANIES BE LIABLE FOR SPECIAL, CONSEQUENTIAL OR INCIDENTAL DAMAGES, EXCEPT AS SPECIFICALLY STATED IN THESE TERMS AND CONDITIONS OF SALE. THE SOLE REMEDY WITH RESPECT TO ANY PRODUCT OR PART SOLD OR INSTALLED BY HEAT-TIMER CORPORATION SHALL BE LIMITED TO THE RIGHT TO REPLACEMENT OR REPAIR F.O.B. FAIRFIELD, NJ. HEAT-TIMER CORPORATION SHALL NOT BE LIABLE OR RESPONSIBLE FOR LOSS OR DAMAGE OF ANY KIND RESULTING FROM DELAY OR INABILITY TO DELIVER FOR ANY REASON, INCLUDING BUT NOT LIMITED TO FIRE, FLOOD, LIGHTNING, POWER FAILURE OR SURGES, UNAVAILABILITY OF PARTS, STRIKES OR LABOR DISPUTES, ACCIDENTS AND ACTS OF CIVIL OR MILITARY AUTHORITIES.

03122010

SPECIFICATION

Operating Temperature	20°F/-6°C to 120°F/49°C
Voltage Input:	120 VAC 60 Hz
Maximum Input Rating:	6 VA Max
Pump Outputs	3 Pump Relays (each relay provide 120 VAC 60Hz. Max ¼ HP)
Solenoid Valve Outputs	2 Solenoid Valve Relays (each relays provide 120 VAC 60Hz. Max 80VA)
Alarm Outputs	2 Alarm Relays (Relays are SPST do not source any power)
Output Relay Rating:	1 Amp inductive, 6 Amp resistive at 120 VAC 60 Hz, 15A total for all circuits
2-Pump Operating Modes	2-Pump (1-Call 1-Flow), (1-Call 2-Flow)
3-Pump Operating Modes	3-Pump (1-Call 1-Flow), (2-Call 2-Flow), (3-Call 3-Flow)
3-Pump 3-Call 3-Flow Delay options	Off or 6 minutes (Dip Switch 4)
LED:	10 (3 Pumps), (2 Solenoid), (3 Alarms), 1 Power, and 1 Comm (future use)
Inputs:	3 Pump Call inputs (Dry-Contact), 3 Flow inputs (Dry-Contact)
Rotation Options	Per Call, 1 day, and 7 Day
Pump Exercise Options	On (10 seconds per 1 week of no operation per pump), Off
Pump Alarm Delay	30 seconds fixed
Buttons:	Manual reset
Dip Switches:	Total 8
Fuse:	20 mm 5 amp
Dimensions:	.7 1/8" W x 9 5/8" H x 3 1/2"D
Weight:	.2 pounds

HT# 059296-00A



20 New Dutch Lane, Fairfield, NJ 07004
Ph: (973) 575-4004 • Fax: (973) 575-4052
<http://www.heat-timer.com>