Model 243 Service Regulators

R-1306
Rev. 9



invensys
Metering Systems

243 Service Regulators

These large capacity service regulators are designed and built for commercial, industrial and gas distribution work. They are right at home in such places as factories and foundries, district regulator stations, commercial laundries and laundromats, motels-hotels and apartments, bakeries, restaurants, schools, churches and hospitals.

The versatile 243 is used for all kinds of gas fueled equipment ...boilers, burners, furnaces, ovens, heaters, kilns, engines, air conditioners, etc.

Remarkable field versatility results from the union connection between the fully interchangeable bodies and diaphragm-case

assemblies. They are easy to install, adjust, inspect and service in all kinds of piping arrangements.

While used primarily for natural gas services, Model 243 regulators perform equally well on LPG vapor, air, dry CO₂, nitrogen and other inert gas applications. Please contact your representative for special construction which may be available for certain corrosive gases.

As a standard service regulator, or a variation from pages 6 and 7, try a top performance 243 on your next application.

Basic Models

243-12 Model Numbers	Variation	243-8 Model Numbers
243-12-1	Standard* Regulator	243-8-1
243-12-2	Regulator with Internal Relief Valve (IRV)	243-8-2
243-12-4	Regulator with Low Pressure Cut-off (LPCO)	243-8-4
243-12-6	Regulator with both IRV and LPCO	243-8-6
	High Pressure Regulator	243-8HP
	Pressure Loaded Regulator	243-8PL

† For additional information on IRV refer to page 5. For LPCO refer to page 6
*The term standard refers to non-IRV configurations.

Outlet Pressure Ranges and Springs

Spring Color	Outlet Pressure Range		Spring Part Number
	243-12	243-8	
Red-Black	—	3 1/2" to 6 1/2" w.c.	143-82-021-00
Blue-Black	—	5" to 8 1/2" w.c.	143-82-021-01
Green-Black	—	6" to 14" w.c.	143-16-021-02
Red	3 1/2" to 6 1/2" w.c.	—	143-16-021-03
Blue	5" to 8 1/2" w.c.	—	143-16-021-04
Green	6" to 14" w.c.	12" to 28" w.c.	143-16-021-05
Orange-Black	10" to 18" w.c.	—	143-16-021-11
Orange	12" to 28" w.c.	1 to 2 psi	143-16-021-06
Black	1 to 2 psi	2 to 4 1/2 psi	143-16-021-07
Cadmium	1 1/2 to 3 psi	3 to 5 psi*	143-16-021-08
Cadmium	1 1/2 to 3psi	3 to 6 1/2 psi*	143-16-021-08
Cadmium	—	6 to 10 psi*	143-16-021-08
White†	—	—	143-16-021-13

†White is nested inside Cadmium.

*Model 243-8HP only.

* Model 243-8-2 (IRV) only.

Pipe Sizes

Model	Pipe Size
243-12-1 and 243-12-2	1 1/4", 1/2" and 2"
243-8-1 and 243-8-2	1 1/4", 1 1/2" and 2"
243-8HP	1 1/4", 1 1/2" and 2"

Temperature Limits

The Model 243 Regulator may be used for flowing gas temperatures from -20°F to 150°F.

Buried Service

The Model 243 Regulator is not recommended for buried service.

Maximum Inlet Pressure, psig

Regulator Model and Size	Orifice Size and Angle									
	1 1/4"	1 1/2"	1"	1 1/2"	3/4"	3/4"	1/2"	3/4"	1/2"	.207"
	30°	10°	30°	10°	30°	10°	10°	10°	10°	10°
1 1/4", 243-12	15	25	25	40	-	60	100	125	125	-
1 1/2", 243-12	15	25	25	40	-	60	100	125	125	-
2", 243-12	15	25	25	40	40	60	100	125	125	-
1 1/4", 243-8	-	-	-	-	-	40	80	100	125	125
1 1/2", 243-8	-	-	25	-	-	40	80	100	125	125
2", 243-8	-	-	25	-	40	40	80	100	125	-
1 1/4", 243-8HP	-	-	-	-	-	40	80	100	125	-
1 1/2", 243-8HP	-	-	25	-	-	40	80	100	125	-
2", 243-8HP	-	-	25	-	-	40	80	100	125	-

*External Control Regulator Only

Fixed Factor Billing

Regulator accuracy is essential to measurement accuracy, and because the 243 is so precise, it is ideal for Pressure-Factor Measurement, Pressure Compensated Metering, Fixed Factor Billing, etc.

The table below gives the pressure accuracies obtainable with 243-12 and 243-8 regulators at the capacities in the tables on pages 8 to 19.

The 243 will hold outlet pressure within the indicated percentage limits from set flow (250 scfh) to the flows given in the capacity tables. Percentages are all based on absolute pressure using 14.4 psia as atmospheric.

As an example, referring to page 10, a 1 1/4" Model 243-12-2 with 1" orifice, 30° valve, 15 psig inlet and 11" w.c. set-point (green spring) at 2" w.c. droop has a gas capacity of 9800 scfh. Per the below table, this regulator at these conditions will hold outlet pressure at 11" w.c. \pm 1/2% (2" w.c.) from 250 to 9800 scfh (based on absolute pressure).

For higher outlet pressures and greater capacities, where the above accuracies become inadequate, use the 243-RPC pilot operated regulator (see page 7). Use it also to maintain accuracy where there are excessive variations in the inlet pressure.

Set Point	Droop	Accuracy
6" w.c.	1" w.c.	+ 1/2% and - 1/2%
7" w.c.	1" w.c.	+ 1/2% and - 1/2%
11" w.c.	2" w.c.	+ 1/2% and - 1/2%
18" w.c.	3" w.c.	+ 1% and - 1%
1 psi	0.31 psi	+ 1% and - 2%
1 psi	0.2 psi	+ 1% and - 1 1/2%
2 psi	0.6 psi	+ 1% and - 4%
3 psi	0.35 psi	+ 1% and - 2%
3 psi	0.6 psi	+ 1% and - 3 1/2%

Construction and Design Features

Model 243-8-1

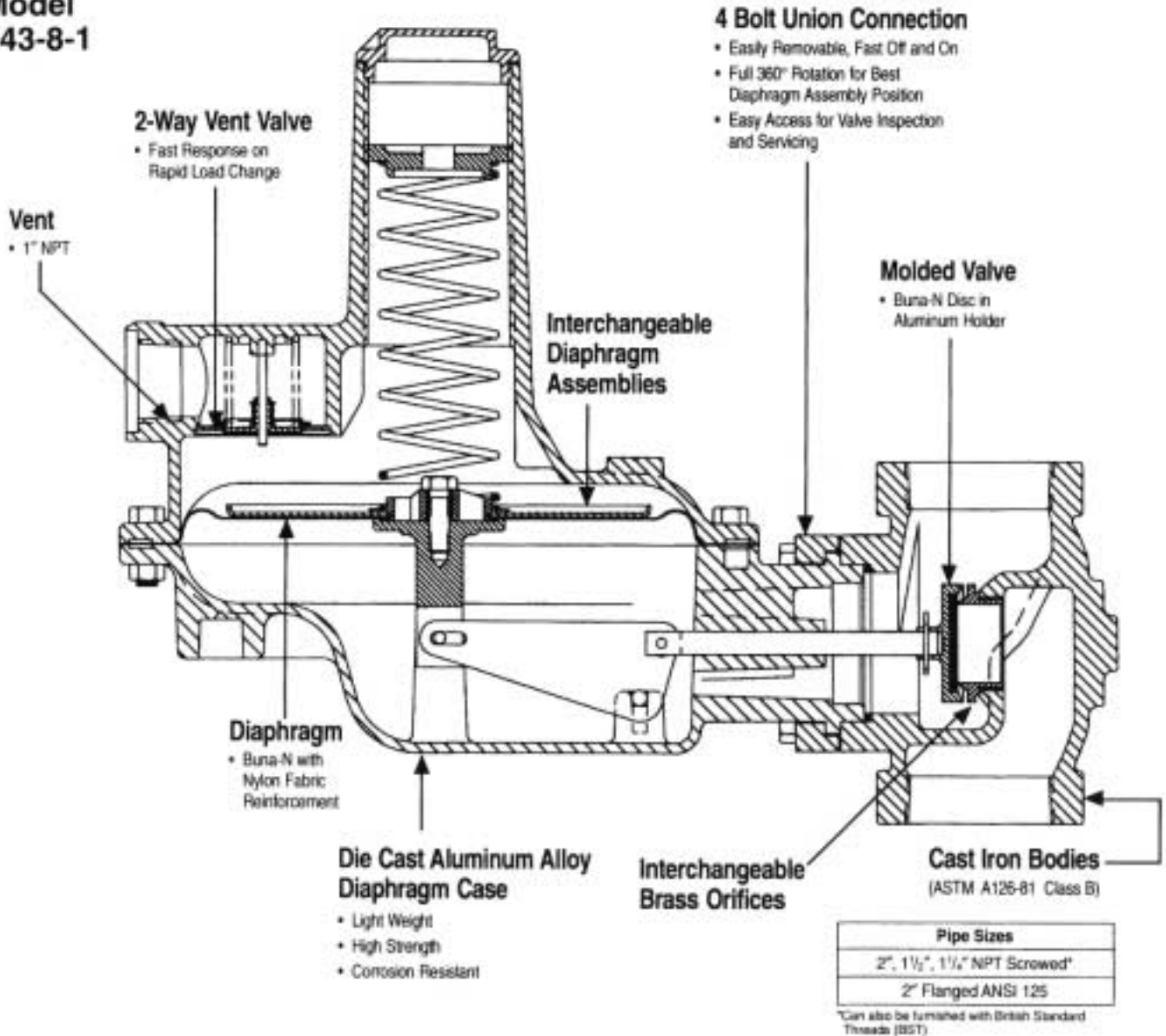

Model 243-12-1 Travel Stop

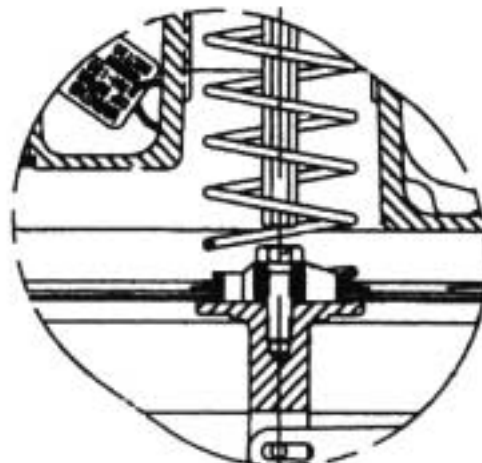

A travel stop is located in the 243-12-1 and the 243-12-4 to provide overpressurization protection.

Caution: Turn gas on slowly. If an outlet stop valve is used, it should be opened first. Do not overload the diaphragm with a sudden surge of inlet pressure. Monitor the outlet pressure during start-up to prevent an outlet pressure overload. Refer to RM-1306 for more detailed start-up procedures.

Operation of the Internal Relief Valve

The internal relief valve is optional (refer to Basic Models Table, page 2).

Often called an "IRV", it is built into the center of the diaphragm assembly as shown in the adjoining sketch, and works in essentially the same way as standard relief valves.

It opens when outlet pressure exceeds the setpoint by approximately 9" w.c. thereby allowing excess gas to escape through the vent to atmosphere. An optional spring is available on the 243-8-2 for relieving at approximately 20" w.c. above set point. A cross-section of a complete 243 with IRV is shown on page 6.

Performance is given on the curves at the right. The IRV will prevent the outlet pressure from exceeding the value shown by the curves upon regulator failure at the conditions specified.

The IRV is a proven design of quality construction. Within its capacity limits it adds a measure of safety protection to the outstanding and dependable performance of the 243.

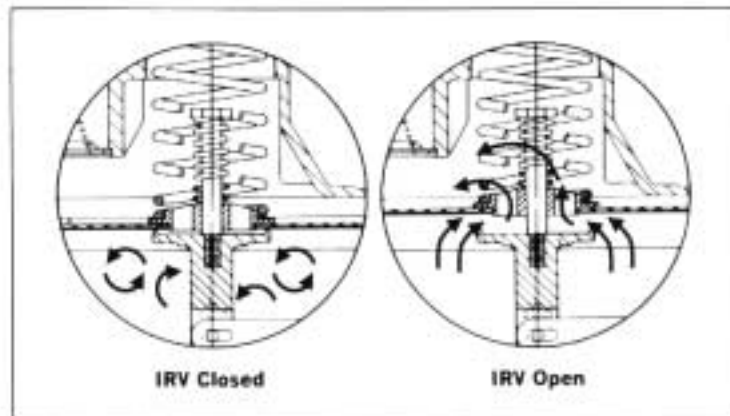
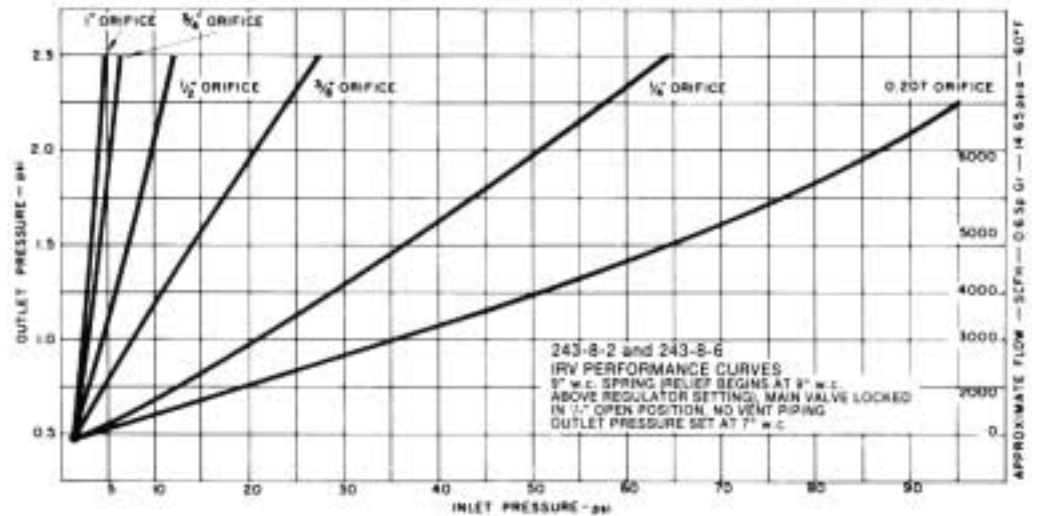
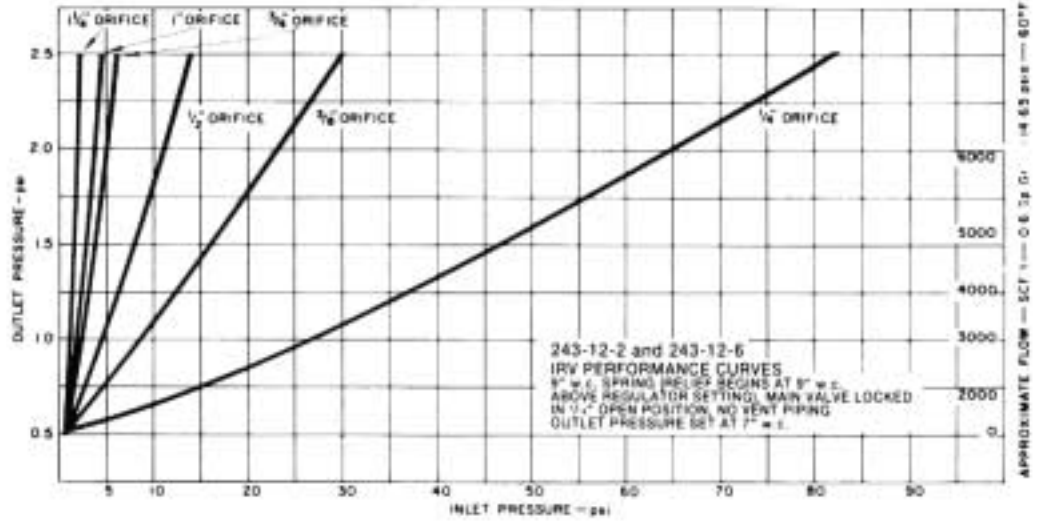

CAUTION: Note that an IRV, like any relief valve, must be sized carefully. If the curves indicate that outlet pressure can exceed the maximum safe limit it is essential an additional relief valve carefully sized to handle the difference.

243 Variations

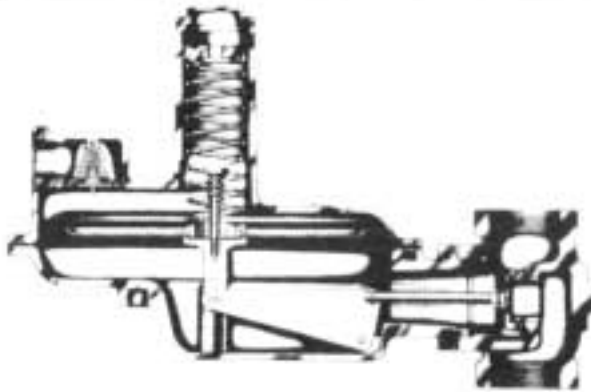

Internal Relief Valve

The 243 is available with an internal relief valve (IRV). It's a built-in safety device for providing a limited level of over-pressure protection.

Like any relief valve, an IRV must be carefully sized.

More complete description plus performance data is given on page 5. For Basic Models refer to the table on page 2.

Internal relief valves are not available in the high pressure Model 243-8HP.

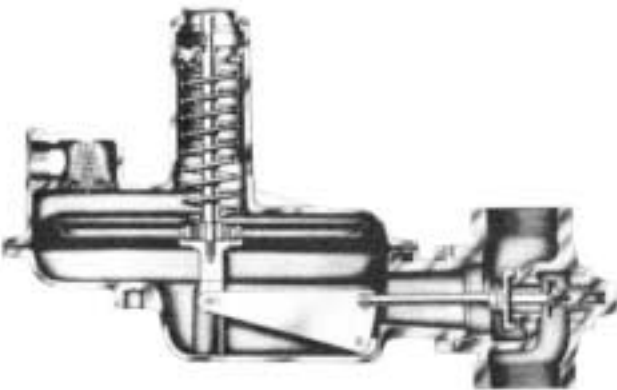

Low Pressure Cut-Off

The low pressure cut-off (LPCO) is used for automatic gas shutoff when inlet pressure is too low for the required gas flow. Once closed, it must be manually reopened and reset.

Basic Models are given in the table at the bottom of page 2. Note: There is an LPCO version that also includes the internal relief valve.

Outlet pressures range from 4" w.c. to 30" w.c. and available orifices are 1/2", 3/4" and 1". For more complete information and capacities please refer to data bulletin RDS 1306-1.

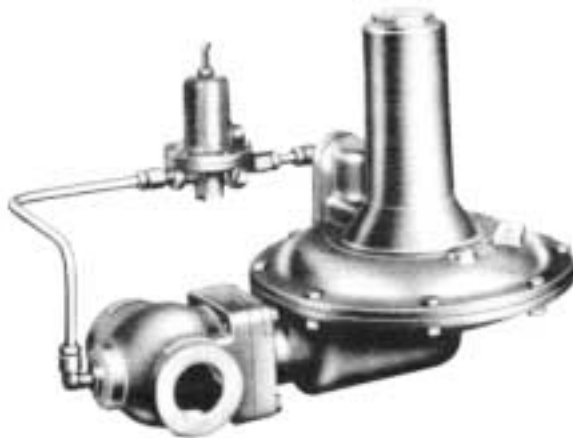

Pressure Loading

While pressure loading (self-operation) falls short of the remarkable accuracy inherent in the pilot operated regulator (relay-operation) it still does a good job. And the pressure loaded 243-8PL has a performance background of many years of dependable, accurate pressure control.

Its outlet range is 1 to 35 psig. Pipe sizes are 1/4", 1/2" and 2". It is available arranged either bleed to atmosphere or bleed to line. And capacity ranges to over 50,000 scfh.

Monitoring and External Control Line

This 243 is used for the first regulator (upstream regulator) in a monitor set or for other applications requiring an external downstream control line.

A throat block with an o-ring stem seal isolates the lower diaphragm chamber which has a 1/2" FNPT connection for the external control line.

Use of this regulator for monitoring is shown on page 20. Capacity with the external control line is given on pages 12 and 13.

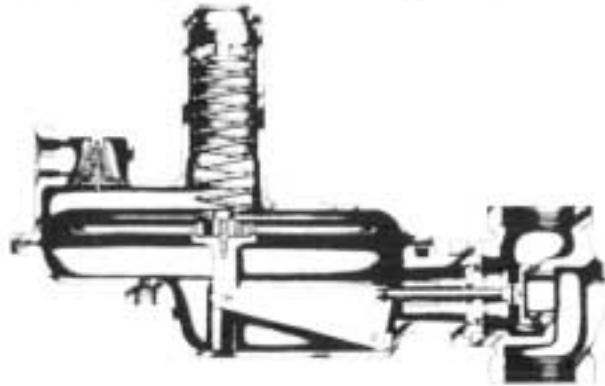

Pilot Operated Regulator

The 243-RPC is a genuine pilot operated regulator. It works on exactly the same relay-operation principle as the widely used models 1100 and 1200, and the 441-VPC.

Like its bigger brothers, it not only provides remarkably precise pressure regulation but it maintains that high level of accuracy even for wide variations in inlet pressure.

The 243-RPC can be used for any outlet pressure from 3 1/2" w.c. to 35 psig with capacity ranging as high as 75,000 scfh.

For detailed information please refer to Bulletin R-1343.



Model 243 Capacity Tables

2" Models 243-12-1 and 243-12-2 in SCFH of Natural Gas (0.6 Specific Gravity—14.65 psia—60°F)

Outlet Pressure and Spring	Inlet Pressure psi	Orifice Size and Valve Angle						
		1½"	1"	¾"	½"	¼"	¼"	¼"
		30°	30°	30°	10°	10°	10°	10°
Set Point 6" w.c. 1" w.c. Droop Red Spring 3½" to 6½" w.c. 143-16-021-03	½	2400	2200	1500	1250	800	500	
	1	4000	3600	2700	2100	1300	850	400
	2	6400	6000	4500	3800	2200	1400	600
	5	11000	11000	8200	6500	3800	2300	1000
	10	13000	15000	12500	9000	5700	3300	1500
	15	14000	15000	15000	10300	7100	4000	1750
	25		15000	20000	11500	9500	5300	2400
	40			20000	13000	13000	7500	3300
	60				15000	13000	10000	4500
	80					13000	12000	5700
	100					13000	12000	7000
	125						12000	8000
Set Point 7" w.c. 1" w.c. Droop Blue Spring 5" to 8½" w.c. 143-16-021-04	½	2000	1800	1400	1100	700	500	
	1	3400	3000	2200	2000	1200	750	400
	2	6000	5600	4000	3200	2000	1250	600
	5	11000	11000	8000	6000	3700	2100	1000
	10	12500	14000	12000	8400	5600	3300	1400
	15	14000	15000	15000	10000	7100	4000	1750
	25		15000	20000	11500	9500	5300	2400
	40			20000	13500	12000	7500	3200
	60				15000	13000	10000	4400
	80					13000	12000	5600
	100					13000	12000	7000
	125						12000	8000
Set Point 11" w.c. 2" w.c. Droop Green Spring 6" to 14" w.c. 143-16-021-05	1	3400	3000	2100	1950	1150	750	400
	2	5600	4700	3700	3400	2000	1200	600
	5	10500	9000	7800	6900	3500	2100	1000
	10	13000	13000	12000	9200	5500	3200	1600
	15	14000	14000	15000	10500	7000	4000	1800
	25		15000	20000	12000	9500	5300	2400
	40			20000	14500	12500	7500	3200
	60				15500	13000	10000	4400
	80					14000	12000	5600
	100					14000	12000	7000
	125						12000	8000

Last capacity figure in each group indicates maximum allowable inlet pressure (except for emergency conditions). Heavy stepped line indicates the recommended maximum capacity and inlet pressure for each orifice for operation within the optimum performance range.

Note: The performance data is based on normal testing at 70°F flowing temperature. Changes in performance can occur at extreme low flowing temperatures.

2" Models 243-12-1 and 243-12-2 in SCFH of Natural Gas (0.6 Specific Gravity—14.65 psia—60°F) (continued)

Outlet Pressure and Spring	Inlet Pressure psi	Orifice Size and Valve Angle						
		1½"	1"	¾"	½"	¼"	¼"	¼"
		30°	30°	30°	30°	30°	10°	10°
Set Point 18" w.c. 3" w.c. Droop Orange Spring 12" to 28" w.c. 143-16-021-06	1	2500	2000	1400	1200	950	650	
	2	4200	3400	2700	2400	1500	1000	500
	5	8000	7100	5600	4700	2800	1800	950
	10	12000	12000	10500	7500	4800	2900	1400
	15	13500	14500	15000	9500	6500	3900	1700
	25		16500	20000	11500	9200	5300	2300
	40			20000	13500	12000	7500	3200
	60				15000	13000	10000	4400
	80					14000	12000	5600
	100					14000	12000	7000
125						12000	8000	
Set Point 1 psi 0.31 psi Droop Orange Spring 12" to 28" w.c. 143-16-021-06	2	6500	5000	4000	4000	2000	1300	500
	5	8000	7500	6000	6000	4000	2200	1000
	10	9000	8500	8000	8000	5500	3000	1400
	15	12000	11000	10000	10000	7000	4000	1800
	25		13500	12500	11500	9500	5500	2400
	40			14000	13000	11000	7400	3300
	60				15000	13500	10000	4500
	80					15000	13000	6000
	100					16000	14000	7000
	125						14000	8500
Set Point 1 psi 0.2 psi Droop Black Spring 1 to 2 psi 143-16-021-07	2	3350	3000	2000	1900	1200	1000	500
	5	6600	5900	4200	3900	2400	1600	1000
	10	11000	10000	7600	6500	4100	2800	1450
	15	13000	12000	9300	8300	5600	3800	1700
	25		15000	16500	11000	8500	5300	2400
	40			20000	14000	12500	7500	3400
	60				15500	13000	10000	4400
	80					14000	12000	5600
	100					14000	12000	7000
	125						12000	8000
Set Point 2 psi 0.6 psi Droop Cadmium Spring 1½ to 3 psi 143-16-021-08	5	8200	7400	5200	4800	2900	1900	900
	10	12500	11300	8700	7800	4800	3000	1400
	15	15500	14500	11500	10000	6500	3800	1700
	25		18000	16500	13500	9000	5300	2400
	40			20000	16500	12500	7600	3400
	60				16500	15500	10000	4600
	80					16000	12000	5600
	100					16000	12000	7000
125						12000	8000	
Set Point 3 psi 0.35 psi Droop Cadmium Spring 1½ to 3 psi 143-16-021-08	5	3500	3000	2000	1800	1400	1100	750
	10	8000	7000	5500	5000	3000	2000	1100
	15	10500	10000	8000	7000	4000	3000	1600
	25		11500	9800	9000	5600	4500	2000
	40			21500	20000	10500	7500	3500
	60				21000	14500	10500	4500
	80					18000	13500	6000
	100					20500	16400	7500
125						19000	9000	

Last capacity figure in each group indicates maximum allowable inlet pressure (except for emergency conditions). Heavy stepped line indicates the recommended maximum capacity and inlet pressure for each orifice for operation within the optimum performance range.

Note: The performance data is based on normal testing at 70°F flowing temperature. Changes in performance can occur at extreme low flowing temperatures.

Model 243 Capacity Tables

1 1/2" Models 243-12-1 and 243-12-2 in SCFH of Natural Gas (0.6 Specific Gravity-14.65 psia-60°F)

Outlet Pressure and Spring	Inlet Pressure psi	Orifice Size and Valve Angle					
		1 1/4"	1"	3/4"	1/2"	1/2"	1/4"
		30°	30°	10°	10°	10°	10°
Set Point 6" w.c. 1" w.c. Droop Red Spring 3 1/2" to 6 1/2" w.c. 143-16-021-03	1/2	2000	1600	1300	700	500	
	1	2800	2500	2100	1200	800	400
	2	4000	3500	3200	2100	1300	600
	5	6100	5600	4800	3700	2200	1000
	10	8200	7700	6500	5600	3100	1400
	15	9300	9300	7400	6800	3900	1750
	25		11000	9100	8100	5100	2400
	40			10500	9800	7100	3200
	60			12000	11000	9300	4400
	80				12000	10500	5600
	100				12000	11000	7000
	125					11000	8000
Set Point 7" w.c. 1" w.c. Droop Blue Spring 5" to 8 1/2" w.c. 143-16-021-04	1/2	1800	1550	1100	600	500	
	1	2600	2300	1850	1100	750	400
	2	3800	3300	2600	1900	1250	600
	5	5700	5100	4200	3300	2100	1000
	10	8200	7600	6000	5400	3100	1400
	15	9300	9100	7000	6600	3900	1750
	25		11000	8400	7800	5100	2400
	40			10000	9500	7100	3200
	60			10500	10500	9300	4400
	80				11500	10500	5600
	100				12000	11000	7000
	125					11000	8000
Set Point 11" w.c. 2" w.c. Droop Green Spring 6" to 14" w.c. 143-16-021-05	1	2700	2300	1900	1100	750	400
	2	4000	3500	2700	1900	1200	600
	5	6000	5600	4500	3500	2100	1000
	10	8800	8200	6500	5500	2900	1400
	15	10000	9800	7700	6800	3800	1750
	25		11500	9700	8100	5100	2400
	40			11500	9700	7100	3200
	60			12500	11500	9300	4400
	80				12000	10500	5600
	100				12500	11000	7000
	125					11000	8000
	Set Point 18" w.c. 3" w.c. Droop Orange Spring 12" to 28" w.c. 143-16-021-06	1	1800	1300	1100	800	500
2		3000	2800	2200	1500	1000	500
5		5600	5200	4200	2600	1800	950
10		8600	7700	6000	4300	2900	1400
15		10000	9300	7400	5800	3800	1750
25			11500	9100	7800	5100	2400
40				11000	9500	7100	3200
60				12500	11000	9300	4400
80					12500	10500	5600
100					13000	11000	7000
125						11000	8000

Last capacity figure in each group indicates maximum allowable inlet pressure (except for emergency conditions). Heavy stepped line indicates the recommended maximum capacity and inlet pressure for each orifice for operation within the optimum performance range.

Note: The performance data is based on normal testing at 70°F flowing temperature. Changes in performance can occur at extreme low flowing temperatures.

Model 243 Capacity Tables



1 1/2" Models 243-12-1 and 243-12-2 in SCFH of Natural Gas (0.6 Specific Gravity-14.65 psia-60°F) (con'L)

Outlet Pressure and Spring	Inlet Pressure psi	Orifice Size and Valve Angle					
		1 1/4"	1"	3/4"	1/2"	3/8"	1/4"
		30°	30°	10°	10°	10°	10°
Set Point 1 psi 0.31 psi Droop Orange Spring 12" to 28" w.c. 143-16-021-06	2	6500	5000	4000	2000	1300	500
	5	8000	7500	6000	4000	2200	1000
	10	9000	8500	8000	5500	3000	1400
	15	12000	11500	10000	7000	4000	1800
	25		13500	11500	9500	5500	2400
	40			13000	11000	7400	3300
	60			15000	13500	10000	4500
	80				15000	13000	6000
	100				16000	14000	7000
	125					14000	8500
Set Point 1 psi 0.2 psi Droop Black Spring 1 to 2 psi 143-16-021-07	2	2800	2450	1500	1200	850	500
	5	5500	5100	3700	2400	1600	950
	10	8000	7500	5700	4000	2700	1400
	15	10000	9100	7100	5300	3700	1750
	25		11000	9300	7300	5100	2400
	40			11000	9300	7100	3200
	60			12500	11000	9300	4600
	80				12500	10500	5600
	100				13000	11000	7000
	125					11000	8000
Set Point 3 psi 0.35 psi Droop Cadmium Spring 1 1/2 to 3 psi 143-16-021-08	5	3500	3000	2000	1400	1100	500
	10	7000	6000	5000	2500	2000	1000
	15	9000	8000	7000	3500	2500	1500
	25		10000	8000	4800	4500	1900
	40			11500	6500	6000	3500
	60			14000	8000	7500	4500
	80				9000	8000	6000
	100				12000	11000	7000
	125					12000	8500
	Set Point 2 psi 0.6 psi Droop Cadmium Spring 1 1/2 to 3 psi 143-16-021-08	5	6000	5300	4100	2700	1700
10		10000	9300	7100	4700	2900	1400
15		13000	12000	8800	6200	3800	1700
25			14500	11000	8600	5200	2400
40				13500	11000	7100	3200
60				15000	13500	10000	4600
80					15000	12000	5600
100					16000	12000	7000
125						12000	8000

Last capacity figure in each group indicates maximum allowable inlet pressure (except for emergency conditions). Heavy stepped line indicates the recommended maximum capacity and inlet pressure for each orifice for operation within the optimum performance range.

Note: The performance data is based on normal testing at 70°F flowing temperature. Changes in performance can occur at extreme low flowing temperatures.

Model 243 Capacity Tables

1 1/4", 1 1/2" and 2" Model 243-12-1 with External Control Line in SCFH of Natural Gas

(0.6 Specific Gravity-14.65 psia-60°F)

Outlet Pressure and Spring	Inlet Pressure psi	Orifice Size and Valve Angle					
		1 1/4"	1"	3/4"	1/2"	3/8"	1/4"
		30°	10°	30°	10°	10°	10°
Set Point 6" w.c. 1" w.c. Droop Red Spring 3 1/2" to 6 1/2" w.c. 143-16-021-03	1/2	2200	1900	1600	800	500	
	1	3600	3200	2300	1300	850	400
	2	5600	4700	3500	2000	1400	600
	5	10500	8200	5700	3500	2200	1000
	10	15000	12000	8900	5200	3000	1500
	15	19000	16000	12000	6700	4000	1750
	25	22000	20000	16000	9000	5200	2400
	40		24000	21000	12000	7500	3200
	60			27000	15500	10000	4400
	80				17000	12000	5700
	100				19000	13500	7000
	125					15000	8000
Set Point 7" w.c. 1" w.c. Droop Blue Spring 5" to 8 1/2" w.c. 143-16-021-04	1/2	2000	1700	1500	700	450	
	1	3100	2600	2000	1100	750	400
	2	5000	3800	3000	1700	1200	600
	5	7800	6500	5000	3100	2000	1000
	10	13000	10000	7000	4800	2900	1500
	15	15000	14000	9400	6400	4000	1750
	25	20000	17000	13500	8500	5200	2400
	40		21000	17000	11500	7500	3200
	60			19000	15000	10000	4400
	80				17000	12000	5700
	100				19000	13500	7000
	125					15000	8000
Set Point 11" w.c. 2" w.c. Droop Green Spring 6" to 14" w.c. 143-16-021-05	1	3200	2500	1900	1100	700	350
	2	5200	4200	3200	1800	1300	550
	5	8500	7200	5200	3200	2000	1000
	10	13500	11000	8000	5000	3000	1500
	15	16000	14000	11000	6500	4000	1750
	25	20000	17000	14000	9000	5200	2400
	40		24000	21000	12000	7000	3200
	60			25000	15000	9800	4400
	80				17000	12000	5700
	100				19000	13500	7000
	125					15000	8000

Last capacity figure in each group indicates maximum allowable inlet pressure (except for emergency conditions). Heavy stepped line indicates the recommended maximum capacity and inlet pressure for each orifice for operation within the optimum performance range.

*2" Body Only

Note: The performance data is based on normal testing at 70°F flowing temperature. Changes in performance can occur at extreme low flowing temperatures.

Model 243 Capacity Tables



1 1/4", 1 1/2" and 2" Model 243-12-1 with External Control Line in SCFH of Natural Gas

(0.6 Specific Gravity-14.65 psia-60°F) (con't.)

Outlet Pressure and Spring	Inlet Pressure psi	Orifice Size and Valve Angle					
		1/4"	1"	3/4"	1/2"	3/8"	1/4"
		18°	18°	18°	18°	18°	18°
Set Point 18" w.c. 3" w.c. Droop Orange Spring 12" to 28" w.c. 143-16-021-06	1	2400	2000	1200	900	600	300
	2	4200	3200	2000	1500	1000	500
	5	6500	5500	4100	2700	1600	950
	10	11000	8000	6200	4200	2800	1500
	15	14500	11000	8000	5800	3800	1750
	25	18000	15000	11500	8000	5000	2400
	40		21000	15000	11000	7000	3200
	60			20000	15000	9800	4400
	80				17000	12000	5700
	100				19000	13500	7000
	125				15000	8000	
Set Point 1 psi 0.2 psi Droop Black Spring 1 to 2 psi 143-16-021-07	2	3500	2900	1700	1300	850	500
	5	7000	5400	4000	2600	1600	950
	10	10500	8500	5800	4000	2800	1500
	15	14500	10500	7600	5400	3800	1750
	25	18000	14500	10500	7500	5000	2400
	40		20000	15000	10500	7000	3200
	60			20000	15000	9800	4400
	80				17000	12000	5700
	100				19000	13500	7000
		125				15000	8000
Set Point 2 psi 0.6 psi Droop Cadmium Spring 1 1/2 to 3 psi 143-16-021-08	5	8600	6800	5300	2700	1900	850
	10	13000	10500	7500	4500	2900	1400
	15	17500	13500	10500	6000	3800	1750
	25	25000	20000	14000	8500	5000	2400
	40		25000	20000	12000	7000	3200
	60			25000	15000	10000	4400
	80				17000	12000	5700
	100				19000	13500	7000
		125				15000	8000

Last capacity figure in each group indicates maximum allowable inlet pressure (except for emergency conditions). Heavy stepped line indicates the recommended maximum capacity and inlet pressure for each orifice for operation within the optimum performance range.

* 2" Body Only

Note: The performance data is based on normal testing at 70°F flowing temperature. Changes in performance can occur at extreme low flowing temperatures.

Model 243 Capacity Tables

1½" and 2" Models 243-8-1 and 243-8-2 in SCFH of Natural Gas

(0.6 Specific Gravity–14.65 psia–60°F)

Outlet Pressure and Spring	Inlet Pressure psi	Orifice Size and Valve Angle					
		1"	¾"	½"	¾"	½"	0.297"
		30°	10°	10°	10°	10°	10°
Set Point 6" w.c. 1" w.c. Droop Red-Black Spring 3½" to 6½" w.c. 143-82-021-00	½	1100	900	700	500		
	1	1950	1600	1050	750	350	
	2	3200	2400	1550	1000	550	350
	5	5200	3900	2700	1900	950	550
	10	7400	5800	4500	3000	1350	900
	15	9100	7100	5800	3800	1700	1150
	25	12500	8700	7200	5100	2400	1500
	40		10500	9200	7100	3200	2100
	60			11000	9300	4400	2900
	80			11500	10500	5600	3700
	100				11000	7000	4500
	125					8000	5600
Set Point 7" w.c. 1" w.c. Droop Blue-Black Spring 5" to 8½" w.c. 143-82-021-01	½	1000	750	650	400		
	1	1600	1150	900	650	300	
	2	2700	1800	1350	950	450	350
	5	4800	3500	2350	1600	770	500
	10	7000	5400	3900	2500	1250	900
	15	9100	7000	5000	3500	1700	1150
	25	12500	8700	6600	5100	2400	1500
	40		10500	9000	7100	3200	2100
	60			11000	9300	4400	2900
	80			11500	10500	5600	3700
	100				11000	7000	4500
	125					8000	5600
Set Point 11" w.c. 2" w.c. Droop Green-Black Spring 6" to 14" w.c. 143-82-021-02	1	1650	1150	1000	650	300	
	2	2700	2000	1400	1000	450	350
	5	4800	3800	2600	1750	900	600
	10	7000	5400	4200	2800	1300	900
	15	9000	7400	5500	3600	1700	1100
	25	11000	8800	7500	5100	2400	1500
	40		11000	9600	7100	3200	2100
	60			11000	9300	4400	2900
	80			11500	10500	5600	3700
	100				11000	7000	4500
	125					8000	5600

Last capacity figure in each group indicates maximum allowable inlet pressure (except for emergency conditions). Heavy stepped line indicates the recommended maximum capacity and inlet pressure for each orifice for operation within the optimum performance range.

Note: The performance data is based on normal testing at 70°F flowing temperature. Changes in performance can occur at extreme low flowing temperatures.

Model 243 Capacity Tables



1½" Models 243-8-1 and 243-8-2 in SCFH of Natural Gas

(0.6 Specific Gravity—14.65 psia—60°F)

Outlet Pressure and Spring	Inlet Pressure psi	Orifice Size and Valve Angle					
		1"	¾"	½"	¼"	¼"	0.267"
		30°	18°	18°	10°	18°	18°
Set Point 1 psi 0.31 psi Droop Green Spring 12" to 28" w.c. 143-16-021-05	2	4000	3500	1800	1200	500	
	5	6000	5000	3500	2200	1000	
	10	7500	7000	5000	3000	1500	
	15	9000	8000	6500	4000	1850	
	25	12000	10000	8000	5000	2000	
	40		12500	9500	7000	3000	
	60			11500	9500	4500	
	80			12500	11500	6000	
	100				12500	7000	
	125					8000	
Set Point 1 psi 0.2 psi Droop Orange Spring 1 to 2 psi 143-16-021-06	2	2100	1650	1200	850	450	
	5	4000	3200	2100	1300	850	550
	10	6500	5200	3100	2200	1300	800
	15	8400	6500	4400	3000	1700	1000
	25	11000	8600	6500	4400	2400	1500
	40		11000	8600	6700	3200	2100
	60			10500	9000	4400	2900
	80			11500	10500	5600	3700
	100				11000	7000	4500
	125					8000	5600
Set Point 3 psi 0.35 psi Droop Black Spring 2 to 4½ psi 143-16-021-07	5	3000	1800	1200	1100	900	
	10	4000	2500	1800	1500	1000	
	15	5200	4000	2850	2000	1400	
	25	7000	5200	3600	3100	1800	
	40		9000	5000	4200	2200	
	60			8300	6500	3000	
	80			10000	8500	5000	
	100				9000	6000	
	125					8000	
Set Point 3 psi 0.6 psi Droop Black Spring 2 to 4½ psi 143-16-021-07	5	4400	3400	2400	1600	800	
	10	7100	5900	3600	2400	1300	750
	15	9600	7500	4800	3400	1700	1000
	25	12500	10500	6500	5000	2400	1500
	40		13000	9600	7000	3200	2100
	60			12500	9300	4400	2900
	80			13500	11000	5600	3700
	100				12000	7000	4500
	125					8000	5600
Set Point 18" w.c. 3" w.c. Droop Green Spring 12" to 28" w.c. 143-16-021-05	1	1500	1100	800	550		
	2	2100	1700	1300	900	450	350
	5	4500	3400	2000	1350	850	600
	10	6600	5700	3500	2400	1300	850
	15	8800	7100	5000	3400	1700	1050
	25	11500	9100	7100	5100	2400	1500
	40		11000	9300	7100	3200	2100
	60			11000	9400	4400	2900
	80			12000	10500	5600	3700
	100				11000	7000	4500
125					8000	5600	

Last capacity figure in each group indicates maximum allowable inlet pressure (except for emergency conditions). Heavy stepped line indicates the recommended maximum capacity and inlet pressure for each orifice for operation within the optimum performance range.

Note: The performance data is based on normal testing at 70°F flowing temperature. Changes in performance can occur at extreme low flowing temperatures.

Model 243 Capacity Tables

1 1/4" Models 243-8-1, 243-8-2, 243-12-1 and 243-12-2 in SCFH of Natural Gas (0.6 Specific Gravity — 14.65 psia — 60°F)

Outlet Pressure and Spring	Inlet Pressure psi	Orifice Size and Valve Angle				
		1/4"	1/2"	3/4"	1"	0.287"
		10°	10°	10°	10°	10°
Set Point 6" w.c. 1" w.c. Droop Red-Black Spring 3 1/2" to 6 1/2" w.c. 143-82-021-00	1/2	900	700	500		
	1	1600	1050	750	350	
	2	2250	1500	1000	550	350
	5	2500	2200	1900	950	550
	10	3100	2900	2650	1350	900
	15	3550	3600	2700	1700	1050
	25	4200	3800	3300	2400	1500
	40	4200	4100	3800	3200	2100
	60		4800	4400	4400	2900
	80		5600	5600	5600	3700
	100			6000	6000	4500
	125				6000	5600
Set Point 7" w.c. 1" w.c. Droop Blue-Black Spring 5" to 8 1/2" w.c. 143-82-021-01	1/2	750	650	400		
	1	1150	900	650	300	
	2	1700	1300	950	450	350
	5	2300	1900	1600	770	500
	10	2900	2600	2200	1250	900
	15	3500	3100	2500	1700	1050
	25	4200	3600	3300	2400	1500
	40	4800	4000	3800	3200	2100
	60		4600	4400	4400	2900
	80		5600	5600	5600	3700
	100			6000	6000	4500
	125				6000	5600
Set Point 11" w.c. 2" w.c. Droop Green-Black Spring 6" to 14" w.c. 143-82-021-02	1	1150	1000	650	300	
	2	1850	1350	1000	450	350
	5	2500	2200	1750	800	550
	10	2900	2700	2450	1300	900
	15	3700	3850	2600	1700	1100
	25	4250	4000	3300	2400	1500
	40	5300	4200	3800	3200	2100
	60		4850	4400	4400	2900
	80		5850	5600	5600	3700
	100			6000	7000	4500
	125				8000	5600
	Set Point 18" w.c. 3" w.c. Droop Green Spring 12" to 28" w.c. 143-16-021-05	1	1100	800	500	
2		1900	1250	900	450	350
5		2250	1700	1350	750	550
10		2950	2250	2100	1300	850
15		3450	3600	2450	1700	1050
25		4400	3750	3300	2400	1500
40		5300	4100	3800	3200	2100
60			4800	4400	4400	2900
80			4850	5600	5600	3700
100				6000	7000	4500
125					8000	5600

Last capacity figure in each group indicates maximum allowable inlet pressure (except for emergency conditions). Heavy stepped line indicates the recommended maximum capacity and inlet pressure for each orifice for operation within the optimum performance range.

Note: The performance data is based on normal testing at 70°F flowing temperature. Changes in performance can occur at extreme low flowing temperatures.

Model 243 Capacity Tables



1 1/4" Models 243-8-1, 243-8-2, 243-12-1 and 243-12-2 in SCFH of Natural Gas (0.6 Specific Gravity — 14.65 psia — 60°F) (continued)

Outlet Pressure and Spring	Inlet Pressure psi	Orifice Size and Valve Angle				
		3/4"	1/2"	3/8"	1/4"	0.207"
		10°	10°	10°	10°	10°
Set Point 1 psi 0.31 psi Droop Green Spring 12" to 28" w.c. 143-16-021-05	2	3000	1800	1200	500	
	5	4000	3000	2000	1000	
	10	5000	4000	3000	1500	
	15	6000	5100	3900	1900	
	25	7500	6400	4500	2200	
	40	8000	7400	6100	2600	
	60		8000	7350	4000	
	80		8500	8000	5100	
	100			8500	6500	
	125				7000	
Set Point 1 psi 0.2 psi Droop Orange Spring 1 to 2 psi 143-16-021-06	2	1850	1150	850	450	
	5	2100	1700	1350	750	500
	10	2700	2000	1950	1300	800
	15	3150	3100	2050	1700	1000
	25	4150	3250	2850	2400	1500
	40	5300	3800	3600	3200	2100
	60		4600	4250	4400	2900
	80		4650	5600	5600	3700
	100			6000	7000	4500
	125				8000	5600
Set Point 3 psi 0.35 psi Droop Black Spring 2 to 4 1/4 psi 143-16-021-07	5	1200	1000	800	500	
	10	2000	1800	1400	1000	
	15	3300	2800	1800	1400	
	25	4700	3300	2300	1650	
	40	6300	4900	2800	2000	
	60		5800	5000	2800	
	80		6500	6400	4600	
	100			6500	4750	
	125				5000	
Set Point 3 psi 0.6 psi Droop Black Spring 2 to 4 1/4 psi 143-16-021-07	5	2200	1950	1650	700	
	10	3600	2300	2150	1300	750
	15	3800	3400	2350	1700	1000
	25	5000	3900	3250	2400	1500
	40	6300	4300	3700	3200	2100
	60		5500	4400	4400	2900
	80		5500	5850	5600	3700
	100			6550	7000	4500
	125				8000	5600

Last capacity figure in each group indicates maximum allowable inlet pressure (except for emergency conditions). Heavy stepped line indicates the recommended maximum capacity and inlet pressure for each orifice for operation within the optimum performance range.

Note: The performance data is based on normal testing at 70°F flowing temperature. Changes in performance can occur at extreme low flowing temperatures.

Model 243 Capacity Tables

2" Models 243-8-1 and 243-8-2 in SCFH of Natural Gas

(0.6 Specific Gravity—14.65 psia—60°F)

Outlet Pressure and Spring	Inlet Pressure psi	Orifice Size and Valve Angle					
		1"	¾"	½"	¼"	⅜"	⅝"
		30°	30°	15°	10°	15°	10°
Set Point 18" w.c. 3" w.c. Droop Green Spring 12" to 28" w.c. 143-16-021-05	1	1500	1200	1100	800	600	
	2	2400	1800	1700	1250	950	500
	5	5500	3700	3500	2300	1400	900
	10	9400	8400	6000	3700	2400	1400
	15	12000	12000	8100	5600	3800	1700
	25	14500	17500	10000	8200	5600	2400
	40		20000	12000	11500	7400	3400
	60				13500	10000	4600
	80				14000	11000	5600
	100					12000	7000
125						8000	
Set Point 1 psi 0.31 psi Droop Green Spring 12" to 28" w.c. 143-16-021-05	2	5000	4000	4000	3000	1000	500
	5	8000	7000	7000	4000	1900	1000
	10	14000	12800	10000	5500	3000	1500
	15	16500	14000	13900	7750	4500	1800
	25	17700	16900	15000	9000	5500	2500
	40		18000	16500	11500	7400	3200
	60				15000	10000	4600
	80				17000	13800	6100
	100					14000	7000
	125						9000
Set Point 1 psi 0.2 psi Droop Orange Spring 1 to 2 psi 143-16-021-06	2	2400	1800	1700	1200	850	450
	5	4000	3400	3300	2200	1300	900
	10	7000	6000	5400	3500	2200	1400
	15	11000	9000	7000	4600	3100	1700
	25	14500	15000	10000	7400	4800	2400
	40		17500	12000	10500	7000	3400
	60				12500	9500	4600
	80				13500	10500	5600
	100					11000	7000
	125						8000
Set Point 3 psi 0.35 psi Droop Black Spring 2 to 4 ¼ psi 143-16-021-07	5	2000	1600	1600	1400	1000	500
	10	4000	3000	3000	2000	1400	1000
	15	5800	4200	4000	2600	1800	1500
	25	7500	5200	5000	3900	2750	2300
	40		9100	9000	6500	5800	3100
	60				10000	7500	4600
	80				14000	10000	6000
	100					12000	7000
	125						9000
	Set Point 3 psi 0.6 psi Droop Black Spring 2 to 4 ¼ psi 143-16-021-07	5	4400	3400	3300	2400	1600
10		7800	6000	5800	3600	2400	1300
15		11000	9000	7500	4800	3500	1700
25		15000	15000	10500	8000	5100	2400
40			17500	13000	11000	7000	3400
60					14000	9600	4600
80					15000	11000	5600
100						12000	7000
125							8000

Last capacity figure in each group indicates maximum allowable inlet pressure (except for emergency conditions). Heavy stepped line indicates the recommended maximum capacity and inlet pressure for each orifice for operation within the optimum performance range.

Note: The performance data is based on normal testing at 70°F flowing temperature. Changes in performance can occur at extreme low flowing temperatures.

Model 243 Capacity Tables



Model 243-8HP in SCFH of Natural Gas (0.6 Specific Gravity—14.65 psia—50°F)

Outlet Pressure 143-16-021-08	Inlet Pressure psi	1½" Model 243-8HP				1½" Model 243-8HP					2" Model 243-8HP				
		Orifice Size and Valve Angle				Orifice Size and Valve Angle					Orifice Size and Valve Angle				
		¾" 10°	¾" 15°	¾" 10°	¾" 10°	1" 30°	¾" 10°	¾" 10°	¾" 10°	¾" 10°	1" 30°	¾" 10°	¾" 10°	¾" 10°	¾" 10°
Set Point 5 psi 1 psi Droop Cadmium Spring 3 to 6½ psi	10	3300	2050	2000	1300	6000	5500	3200	2300	1300	6000	5500	3200	2400	1300
	15	3400	3100	2200	1700	8600	6500	4400	3200	1700	8600	6000	4400	3200	1700
	25	4400	3650	3050	2400	12000	9300	6100	4800	2400	13000	8200	6100	4800	2400
	40	5800	3800	3200	3200		12000	8500	6100	3200		12000	8700	6100	3400
	60		4400	4100	4400			10000	8700	4400			10000	8700	4600
	80		4500	5300	5600			11000	10000	5600			11500	10000	5600
	100			6000	7000				11000	7000				11000	7000
	125				8000					8000					8000
Set Point 7 psi 1 psi Droop Cadmium- White Springs 6 to 10 psi	10	2300	2000	1800	1000	2500	2300	2000	1600	1000	2700	2500	2100	1600	1000
	15	3000	2800	2200	1400	5000	4000	2500	2200	1500	5900	4300	2800	2400	1500
	25	5400	4100	3300	2000	8500	6500	4300	3500	2000	8600	6600	4600	3600	2000
	40	7600	5600	4800	2800		9500	6500	5000	3000		10000	7200	5600	3000
	60		7500	6200	3800			9000	6500	4000			9700	7000	4500
	80		8800	7200	5200			11000	8500	5000			12000	9000	5500
	100			8600	5800				10500	5500				11500	7000
	125				7000					5500					5500
Set Point 7 psi 2 psi Droop Cadmium- White Springs 6 to 10 psi	10	5400	3500	2500	1400	8000	5500	3500	2500	1300	8600	6000	4300	2700	1400
	15	7400	5000	3500	1800	10500	8000	5000	3500	1700	12700	8900	5700	3800	1800
	25	10000	7600	5500	2500	15000	12000	8000	5000	2300	18600	13500	8600	5700	2400
	40	12500	10000	7500	3500		16000	11500	7500	3300		19000	12500	8000	3500
	60		12500	9500	4800			15000	9500	4500			17000	10000	4800
	80		14000	11500	6100			17500	12500	5500			20000	13500	6200
	100			13500	7200				15500	7000				16500	7300
	125				8800					7000					8100
Set Point 10 psi 1 psi Droop Cadmium- White Springs 6 to 10 psi	15	2500	2200	1800	1200	3500	3000	2000	1300	1000	3600	3000	2000	1800	1000
	25	4800	3500	2800	1900	6500	5000	3500	2500	1900	6800	5700	4000	3000	1900
	40	7200	5000	4000	2500		8000	5500	4300	2500		8600	5700	4600	2800
	60		6700	5700	3500		10500	7500	6000	3500			8600	6400	4300
	80		7800	6600	4600			9000	7500	4500			10500	8400	5200
	100			7800	5400				9500	6000				10700	6500
	125				6500					7000					8000
	Set Point 10 psi 2 psi Droop Cadmium- White Springs 6 to 10 psi	15	6000	4000	2800	1700	8500	6500	4000	2500	1500	9000	6600	4800	3000
25		9000	6500	5000	2500	12000	10500	7000	4500	2300	15500	11000	7400	5000	2400
40		12000	9000	7000	3500		15000	10000	7500	3000		16500	11000	7700	3200
60			12000	9400	4700			14000	10000	4500			15000	10700	4800
80			13000	11000	6000			17000	12000	5500			18500	13000	6000
100				13000	7000				15000	7000				16000	7300
125					8800					9000					9000

Last capacity figure in each group indicates maximum allowable inlet pressure (except for emergency conditions). Heavy stepped line indicates the recommended maximum capacity and inlet pressure for each orifice for operation within the optimum performance range.

Note: The performance data is based on normal testing at 70°F flowing temperature. Changes in performance can occur at extreme low flowing temperatures.

Maximum Emergency Pressures

NOTE: The use of an internal or external relief valve is recommended for installations subjected to no flow for extended periods of time, such as pilotless ignition systems. A travel stop stem is located in the 243-12-1 and 243-12-4 to provide over-pressurization protection to internal components during overpressurization.

The maximum pressure the regulator inlet may be subjected to under abnormal conditions without causing damage to the regulator is the maximum allowable inlet pressure (from the capacity tables, pages 8 through 19) plus 50 psi.

The maximum pressure the diaphragm may be subjected to without causing damage to the internal parts of the regulator is:

243-12-1 set point + 3 psi
 243-12-2, 243-8-1 and
 243-8-2 set point + 5 psi
 243-8 HP set point + 5 psi

Set point is defined as the outlet pressure a regulator is adjusted to deliver.

If any of the pressure limits are exceeded, the regulator must be taken out of service and inspected. Damaged or otherwise unsatisfactory parts must be repaired or replaced.

The maximum pressure that can be safely contained by the diaphragm case is:

243-12-1 and
 243-12-2 15 psi
 243-8-1 and 243-8-2 15 psi
 243-8 HP 25 psi

Safely contained means no leakage as well as no bursting.

Before using any of the above data, make sure this entire section is clearly understood.

Overpressurization Protection

Protect the downstream piping system and the regulator's low pressure chambers against overpressurization due to possible regulator malfunction or failure to

achieve positive lockup. The allowable outlet pressure is the lowest of the maximum pressures permitted by federal codes, state codes, Bulletin RDS-1498 or other

applicable standards. The method of protection can be a relief valve, monitor regulator, shut-off device or similar mechanism.

Monitoring

A monitor set consists of two regulators in series as shown. The monitor is the standby. It takes control if a failure in the operating regulator causes outlet pressure to exceed normal.

Either regulator may be used as the monitor. In both cases the upstream regulator must have a blocked throat and external control line as shown for the 243 on page 7. Also, the control line for the upstream regulator connects into the outlet piping all the way downstream...that is, downstream of the downstream regulator.

The illustration shows a typical 243 monitor set. While the downstream regulator is shown as operating and the upstream regulator shown as the monitor, the two can be reversed. There are reasons for doing it one way or the other depending on user's practice. Stop and bypass valves, not shown, likewise would depend on user's preference and practice.

Either way, the operating regulator is adjusted for the normal outlet pressure. The monitor is adjusted somewhat higher so it is normally full open. If a failure in the

operating regulator causes excessive increase in outlet pressure, the monitor will go into operation to hold outlet pressure at its setpoint.

Monitoring is an effective and dependable method of providing overpressure protection. A significant advantage is that it provides the protection without wasting gas to atmosphere. Refer to Bulletin RDS-1306-2 (Package monitor sets 243-DOT) for more information.

When a 243 is used to monitor another 243 with an identical orifice size, the total maximum capacity through both can be figured at 70% of the rated capacity for one regulator. This applies with the monitor located upstream or downstream.

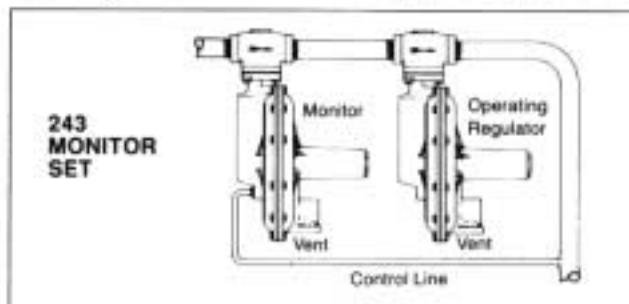

Periodic Inspection: Regulators are pressure control devices with numerous moving parts subject to wear that is dependent upon particular operating conditions. To assure continuous satisfactory operation, a periodic inspection schedule must be adhered to with the frequency of inspection determined by the severity of service and applicable laws and regulations. **See Bulletin RM-1306 field service instructions.**

Mounting Positions

The 243 Service Regulator can be provided in any of the positions shown. Specify by position number when ordering.

CAUTION

The diaphragm case vent must be positioned to protect against flooding, drain water, ice formation, traffic, tampering, etc. The vent must be protected against nest building, animals, bees, insects, etc. to prevent vent blockage and minimize the chances of foreign material from collecting in the vent side.

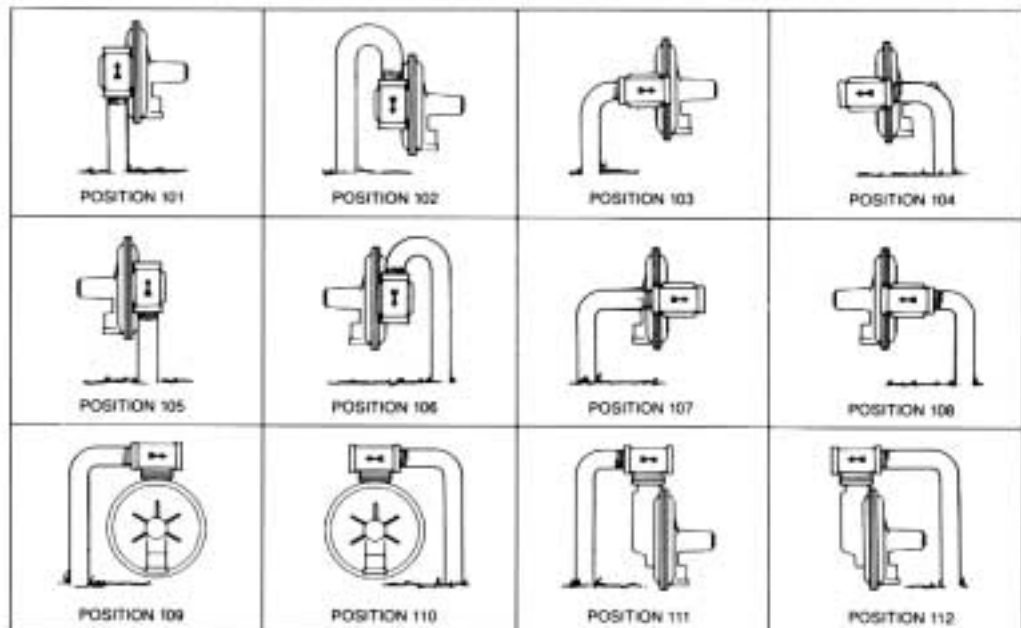

NOTE: If desired position is not shown use diagrams at right as guides to specify vent, diaphragm case, and body arrangement. Example: Position 105 would be D-4-Y.

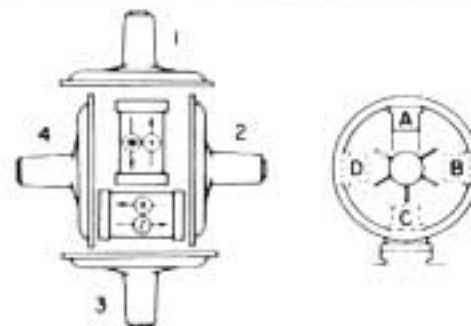

CAUTION: It is the user's responsibility to assure that all service regulator vents and/or vent lines exhaust to a non-hazardous location away from **any potential** sources of ignition. Refer to Bulletin RM-1306 for more detailed information.

Dimensions

Model	243-12	243-8	243-8HP
A	14"	10 1/2"	10 1/2"
** B	9 1/2"	9 1/2"	—
B'	—	—	12 1/2"
C	5 1/2"	5 1/2"	5 1/2"
*** C'	7 1/2"	7 1/2"	7 1/2"
**** C''	7 1/2"	7 1/2"	7 1/2"
D	2 1/2"	2 1/2"	2 1/2"
E	10 1/2"	8 1/2"	8 1/2"
F	6 1/2"	4 1/2"	4 1/2"
G	4 1/2"	4 1/2"	4 1/2"
Shipping* Weight	27 lbs.	25 lbs. 6	29 lbs.

* Add 3 lbs. for flanges on 2" body
 ** 1" for 243-12-1 and 243-12-4, which include bleed stop
 *** ANG Flanges
 **** NG-15 Flanges

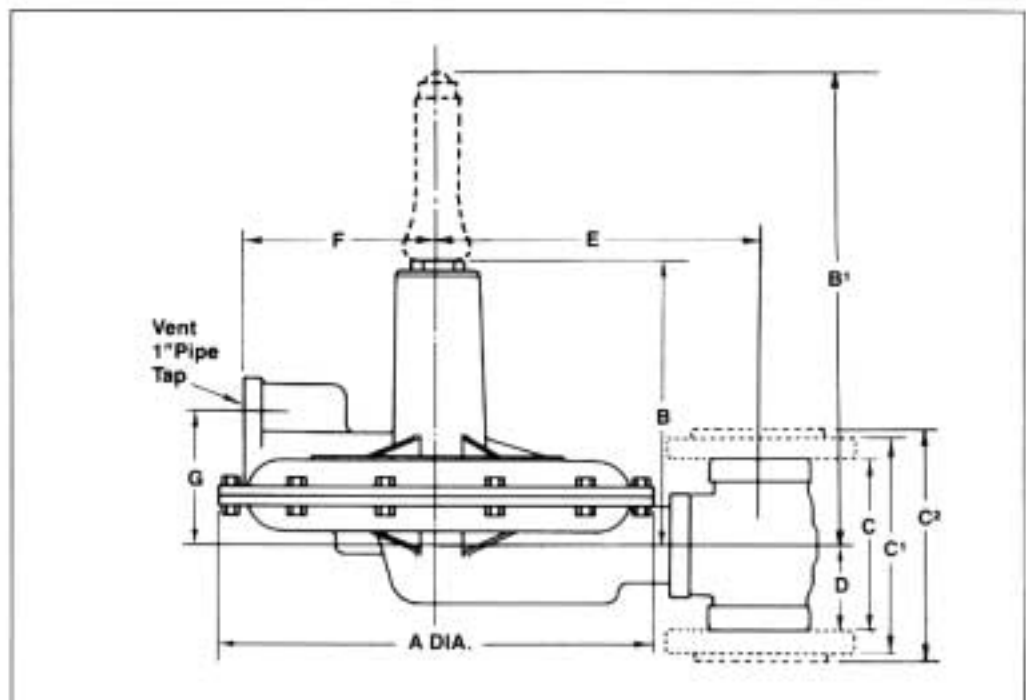

Materials of Construction

Body	Cast Iron
Diaphragm Case	Die Cast Aluminum Alloy
Diaphragm	Buna-N with Nylon Fabric Insert
Diaphragm Pans	Zinc Plated Steel
Diaphragm Coupling	Zinc Die Casting
Orifice	Brass
Valve	Buna-N Soft Seat in Aluminum Holder
Stem	Brass
Lever	Zinc Plated Steel
O-Rings and Tetra Seals	Buna-N
Adjustment Spring Button & Seal Cap, Std.	Zinc Die Casting
Adjustment Screw, 243-8HP	Zinc Plated Steel
Cover, 243-8HP	Cast Iron
Seal Cap, 243-8HP	Cast Iron

Full Open Capacity

Use the following formulae for the full open capacity of 243 regulators.

- $Q = K \sqrt{P_o (P_1 - P_o)}$ (for $\frac{P_1}{P_o}$ less than 1.894)
- $Q = \frac{KP_1}{2}$ (for $\frac{P_1}{P_o}$ greater than 1.894)

Q = maximum capacity of the regulator (in SCFH of 0.6 specific gravity natural gas).
 K = the "K" factor, the regulator constant (from the table).
 P₁ = **absolute** inlet pressure (psia).
 P_o = **absolute** outlet pressure (psia).

Orifice Size-in.	.207"	1/4"	3/8"	1/2"	3/4"	1"	1 1/4"
K	90	132	292	520	1100	1800	2480

When sizing relief valves for use with 243 regulators, use *full open capacity*. Do not use capacity from capacity tables pages 8 thru 19.

Other Gases

243 Regulators are mainly used on natural gas. However, they perform equally well on LP gas, nitrogen, dry CO₂, air and others. For capacities, multiply the table values on pages 8 thru 19 by the following correction factors:

OTHER GASES	CORRECTION FACTOR
Air (Specific Gravity 1.0)	0.77
Propane (Specific Gravity 1.53)	0.63
1350 BTU Propane-Air Mix (1.20)	0.71
Nitrogen (Specific Gravity 0.97)	0.79
Dry Carbon Dioxide (Specific Gravity 1.52)	0.63
For other noncorrosive gases: CORRECTION FACTOR =	$\sqrt{\frac{0.6}{\text{Specific Gravity of the Gas}}}$

While used primarily for natural gas services, Model 243 regulators perform equally well on LPG vapor, air, dry CO₂, nitrogen and other inert gas applications. Please contact your Inversys Metering Systems representative for special construction which may be available for certain corrosive gasses.

How to Order

- Specify:
- Pipe size and model number (page 2).
 - Screwed or flanged connections
 - Mounting position
 - Orifice size and valve angle.
 - Inlet pressure (also maximum and minimum if available)
 - Outlet pressure setting
 - Capacity required (scfh)
 - Type of gas (natural gas, propane, etc.)
 - Spring part number

Other Invensys Metering Systems Gas Pressure Regulators



Invensys Metering Systems produces a broad product line of Gas Pressure Regulators which are widely used throughout the natural gas industry. These regulators are also suitable for non-corrosive industrial gas applications such as propane,

butane, air, nitrogen, dry CO₂, etc. For additional information on a particular model, please request the indicated bulletin from the local Invensys Metering Systems sales office.

Multi-Purpose Service Regulators

Model 043

Bulletin: R-1300

3/8", 1/2", 3/4", 1" pipe size

Inlet pressures to 125 psi

Outlet pressures 3 1/2" w.c. to 2 psi

Capacity to 1000 CFH

Available with 90° angle or straight-through body.

Also available with internal relief valve.

Model 143-6

Bulletin: R-1303

3/4", 1", 1 1/4" pipe size

Inlet pressures to 125 psi

Outlet pressures 3 1/2" w.c. to 6 psi

Capacity to 2000 CFH

Available with 90° angle or straight-through body.

Also available: internal relief valve and low pressure cut-off.

Industrial Field Regulators

For intermediate to high pressure applications. Ideal on pipeline taps servicing plants and buildings. Appropriate for double stage reduction ahead of service regulators, and for high pressure burners and compressed air systems.

046

Bulletin: R-1312

3/4", 1" and 1 1/4" pipe size

Inlet pressures to 1000 psi

Outlet pressures 3 to 200 psi

Capacity to 40,000 SCFH

Monitor and pressure loaded versions, and internal relief valve also available.

141A

Bulletin: R-1311

2" pipe size

Inlet pressures to 1500 psi

Outlet pressures 5 to 400 psi

Capacity to 55,000 SCFH

Pilot Loaded Regulators

For intermediate and high-pressure applications requiring precise pressure reduction with minimal droop. Ideal for standard and high capacity flows on burners, driers, dehydrators and compressor line. Appropriate for fixed factor billing.

243-RPC

Bulletin: R-1343

1 1/4", 1 1/2", and 2" pipe size

Inlet pressures .. to 150 psi

Outlet pressures 3 1/2"

w.c. to 35 psi

Capacity to 76,000 SCFH

1100

Bulletin: R-1341

Pipe size: 2"

(screwed or flanged)

Inlet pressures .. to 400 psi

Outlet pressures 3" w.c.

to 100 psi

Capacity to 414,000 SCFH

1200

Bulletin: R-1342

Pipe size: 2" (flanged)

Inlet pressures to

1200 psi

Outlet pressures 20 to

600 psi

Capacity to 789,000 SCFH

Invensys Metering Systems also produces Industrial and Combustion Regulators: High Pressure, High Capacity Regulators: and Safety Relief Valves. Detailed information available on request.

Invensys Metering Systems
805 Liberty Boulevard, DuBois, PA 15801
(814) 371-8000
FAX (814) 375-8460
www.energymetering.invensys.com

Representatives in all principal cities.
Distributors throughout the world.



Invensys Metering Systems
805 Liberty Boulevard
P.O. Box 528
DuBois, PA 15801

Authorized Distributor:

LIMITED WARRANTY Seller warrants the Goods to be free from defects in materials manufactured by Seller and in Seller's workmanship for a period of [one (1) year] after tender of delivery (the "Warranty Period"). **THIS LIMITED WARRANTY (a) IS IN LIEU OF, AND SELLER DISCLAIMS AND EXCLUDES, ALL OTHER WARRANTIES, STATUTORY, EXPRESS OR IMPLIED, INCLUDING, WITHOUT LIMITATION, ANY WARRANTY OF MERCHANTABILITY OR FITNESS FOR A PARTICULAR PURPOSE, OR OF CONFORMITY TO MODELS OR SAMPLES;** (b) does not apply to any Goods which have been (i) repaired, altered or improperly installed; (ii) subjected to improper use or storage; (iii) used or incorporated with other materials or equipment, after Buyer or anyone using the Goods has, or reasonably should have, knowledge of any defect or non-conformance of the Goods; or (iv) manufactured, fabricated or assembled by anyone other than Seller; (c) shall not be effective unless Buyer notifies Seller in writing of any purported defect or non-conformance within [thirty (30) days] after Buyer discovers or should have reasonably discovered such purported defect or non-conformance; and (d) shall only extend to Buyer and not to any subsequent buyers or users of the Goods. Buyer shall provide Seller access to the Goods as to which Buyer claims a purported defect or nonconformance; upon request by Seller, Buyer shall, at its own risk and expense, promptly return the Goods in question to Seller's Plant.